

Physics 24 Lab Manual

Draft · Spring 2009

Amherst College

Spring 2009

Contents

| | |
|---|-----------|
| General Instructions | 5 |
| 1 Electrostatics | 11 |
| 1.1 Introduction | 11 |
| 1.2 Tape Electrometer | 11 |
| 1.3 Versorium | 12 |
| 1.4 Electrophorus | 13 |
| 1.5 Wimshurst Machines | 13 |
| 1.6 Van de Graaf Generator | 14 |
| 1.7 Kelvin Water Dropper | 14 |
| 1.8 Conclusions | 14 |
| 2 DC Circuits | 15 |
| 2.1 Background | 15 |
| 2.2 Ohm's Law | 20 |
| 2.3 The Laboratory Report | 24 |
| 3 Introduction to the Oscilloscope | 25 |

| | |
|--|-----------|
| | 2 |
| 3.1 Comments | 25 |
| 3.2 Front Panel | 25 |
| 3.3 Procedure | 26 |
| 3.4 Checking Out | 31 |
| 4 Capacitors | 32 |
| 4.1 Summary | 32 |
| 4.2 Theory | 32 |
| 4.3 Measurement of the resistance of a meter. | 34 |
| 4.4 Measuring the “internal resistance” of the function generator. | 35 |
| 4.5 <i>RC</i> Response to a step change in emf. | 36 |
| 4.6 Analysis. | 37 |
| 5 Semiconductor Diodes | 39 |
| 5.1 Introduction | 39 |
| 5.2 Procedure | 42 |
| 5.3 Supplement: Introduction to Semiconductor Diodes | 45 |
| 6 Faraday’s Law and Induction | 51 |
| 6.1 Faraday’s Law Introduction | 51 |
| 6.2 Determining B field strength from the induced EMF | 52 |
| 6.3 Minilabs on Induction | 54 |
| 7 Inductors | 56 |
| 7.1 <i>R-L</i> Circuits (Theory) | 57 |

| | |
|--|-----------|
| | 3 |
| 7.2 The Experiment | 58 |
| 7.3 Analysis: From τ (time constant) to L (inductance). | 59 |
| 8 RLC Circuits | 61 |
| 8.1 Introduction | 61 |
| 8.2 The Experiment: LCR Series Resonance | 66 |
| 8.3 Two Puzzles | 68 |
| 9 Properties of Light | 69 |
| 9.1 Snell's Law | 69 |
| 9.2 Light Intensity Minilabs | 70 |
| 10 Geometric Optics | 74 |
| 11 Interference and Diffraction | 76 |
| A Keeping a Lab Notebook | 80 |
| B Graphical Presentation of Data | 84 |
| B.1 Introduction | 84 |
| B.2 Analyzing your Graph | 85 |
| B.3 Uncertainty Bars | 86 |
| B.4 Presentation Guidelines | 87 |
| C Uncertainty Analysis | 89 |
| C.1 Expressing Experimental Uncertainties | 90 |
| C.2 Determining Experimental Uncertainties | 91 |

| | |
|---|------------|
| | 4 |
| C.3 Propagation of Uncertainties | 92 |
| C.4 Assessing Uncertainties and Deviations from Expected Results | 96 |
| C.5 The User's Guide to Uncertainties | 98 |
| Bibliography | 100 |

General Instructions

The laboratory sessions of Physics 24 are designed to help you become more familiar with fundamental physical concepts by actually carrying out quantitative measurements of physical phenomena. The labs are designed to help you develop several basic skills and several “higher-level” skills. The **basic** skills include the following:

1. Being able to relate abstract concepts to observable quantities. For example, knowing how one determines the electrical resistance of a device from easily measured quantities. This skill includes the ability to estimate and measure important physical quantities at various levels of precision.
2. Knowing and applying some generally useful measurement techniques for improving the reliability and precision of measurements, such as using repeated measurements and applying comparison methods.
3. Being able to estimate the experimental uncertainties in quantities obtained from measurements.

The **higher-level** skills include the following:

1. Planning and preparing for measurements.
2. Executing and checking measurements intelligently.
3. Analyzing the results of measurements both numerically and, wherever applicable, graphically. This skill includes assessing experimental uncertainties and deviations from expected results.
4. Being able to describe, talk about, and write about physical measurements.

The laboratory work can be divided into three parts: **preparation**, **execution**, and **analysis**. The preparation, of course, must be done **before you come to your laboratory session**. The execution and analysis (for the most part) will be done during the three-hour

laboratory sessions. Some suggestions for performing these three parts successfully are given below. Please also refer to Appendix A, **Keeping a Laboratory Notebook**, since good note-taking will be essential in all phases of the lab.

Preparation

1. Read the laboratory instruction carefully. Make sure that you understand what the ultimate **goal** of the experiment is.
2. Review relevant concepts in the text and in your lecture notes.
3. Outline the measurements to be made.
4. Understand how one goes from the measured quantities to the desired results.
5. Organize tables for recording data and the equations needed to relate measured quantities to the desired results.

Execution

1. One of the most important elements of executing the experiment will be keeping a step-by-step record of what you've done, how you've done it, and in what order. Obtain an inexpensive, permanently **bound notebook** (spiral notebooks and binders are not acceptable) for recording your laboratory data, your analysis of the data, and the conclusions you draw from the measured results along with any other relevant comments.

The notebook is an informal record of your work, but it must be sufficiently neat and well-organized so that both you and the instructor can understand exactly what you have done. It is also advantageous for your own professional development that you form the habit of keeping notes on your experimental work — notes of sufficient clarity that you can understand them at a later time. Developing good lab notebook technique requires consistent effort and discipline, skills that will be of great value in any professional career. If you become a research scientist, you will often (while writing reports or planning a new experiment) find yourself referring back to work you have done months or even years before; it is essential that your notes be sufficiently complete and unambiguous that you can understand exactly what you did then. In keeping a laboratory notebook, it is better to err on the side of verbosity and redundancy than to leave out possibly important details.

NEVER ERASE data or calculations from your notebook. If you have a good reason to suspect some data (for example, you forgot to turn on a power supply in the system) or a calculation (you entered the wrong numbers in your calculator), simply draw a line through the data or calculation you wish to ignore and write a comment in the margin. It is surprising how often “wrong” data sets turn out to be useful after

all. In fact, **use a pen to record all of your data** so that you will not fall prey to the temptation to erase.

As mentioned above, Appendix A gives instructions on how to keep a good lab notebook. You will be expected to adhere to these guidelines throughout the semester. In fact, we feel that keeping a good laboratory notebook is so important that **we have decided to base part of your laboratory grade (equivalent to one formal lab report) on the quality of your lab notes. Your notebook will be evaluated at the end of the semester.**

Note: You should **have your lab notebook initialed** by one of the instructors before you leave each lab session.

2. Naturally, you will need to pay attention to your data-taking technique. Throughout the semester, you will be learning how to use various types of measurement equipment, sometimes crude and sometimes sophisticated. In all cases, the quality of your data will depend on your understanding when and how to use the equipment most effectively. It is always more important to put care and thought into the setup for a measurement than it is to attain a (sometimes deceptively) high level of accuracy from a meter. Sure, you will want to optimize the accuracy, but only when you're sure you're making the **right** measurement. For example, if you build a circuit incorrectly, it doesn't matter how many digits you get out of a voltage reading. If the circuit is wired wrong, the results will be wrong, too. So take care to think first, and always critically assess your measurements as you go along to see if they make sense. In fact, this is really a preliminary part of the analysis process.

Analysis

1. In addition to the ongoing analysis you conduct during data-taking, you will be expected to perform a more thorough analysis for each experiment. Most importantly, you will be asked to obtain meaningful physical results from the measurements. Often, though not always, this will be done in the context of a graphical analysis. That is, usually you will use the "method of straight-line graphing" (see Appendix ??) that you have come to know and love (from Physics 16, or its equivalent) to create plots that theoretically "should" be linear. From the slopes of these graphs, you will often be able to determine a result that is effectively an average measurement from all of your data. Of secondary (though not insignificant) importance is the need for you to specify some limits of accuracy about your results. This phase of the operation is often mistakenly referred to as "Error Analysis." In fact, the expression for determining the range of uncertainty in a particular measurement is, appropriately, "Uncertainty Analysis." Below are some guidelines to help with this process.
2. Uncertainties:
The stated results of any measurement is incomplete unless accompanied by the uncertainty in the measured quantity. By the uncertainty, we mean simply: How much

greater, or smaller, than the stated value could the measured quantity have been before you could tell the difference with your measuring instruments? If, for instance, you measure the distance between two marks as 2.85 cm, and judge that you can estimate halves of mm (the finest gradations on your meter stick), you should report your results as 2.85 ± 0.05 cm. More details on uncertainties are given in Appendix C.

An important (if not *the* most important) part of the analysis of an experiment is an assessment of the agreement between the actual results of the experiment and the expected results of the experiment. The expected results might be based on theoretical calculations or the results obtained by other experiments. If you have correctly determined the experimental uncertainty for your results, you should expect your results to agree with the theoretical or previously determined results within the combined uncertainties. If your results do not agree with the expected results, you must determine why. Several common possibilities are the following:

- (a) You underestimated the experimental uncertainties;
- (b) There is an undetected “systematic error” in your measurement;
- (c) The theoretical calculation is in error;
- (d) The previous measurements are in error; or
- (e) Some combination of the above.

Sometimes these deviations are “real” and indicate that something interesting has been discovered. In most cases (unfortunately) the explanation of the deviation is rather mundane (but nevertheless important). Remember that small deviations from expected results have led to several Nobel prizes.

Lab Reports

You will prepare a report for each of the laboratory session. We will have two types: (1) short (informal) reports with an exit interview conducted by one of the laboratory instructors; and (2) longer, written (formal) reports. Both types depend on your having kept a careful record of your work in the lab notebook.

Informal reports will, in general, focus on your in-class record of the experiment during the lab time along with your answers to the questions posed in the handouts for each lab. These short reports need not describe the entire experiment; however, they should be complete and self-contained and distinct from any pre-lab lecture notes which are also written in your lab notebook.

Formal reports will be required for three of the labs (see the Laboratory Syllabus on p. ??). For formal reports, you are to prepare a somewhat longer, written account of your experimental work. These reports should include a complete description of the experiment and its results. They should be typed (you will likely prefer to use a word processor) on separate

sheets of paper (not in your lab notebook) and are to be turned in at the beginning of the subsequent lab period. You should pay special attention to the clarity and conciseness of your writing. In fact, if we find that your report would benefit from rewriting, we may ask you to submit a revised version of the report before a grade is assigned to the report. Guidelines for preparation of formal lab reports are included on a subsequent sheet in this manual.

Grading

You must complete all of the labs to pass Physics 24. If you have to miss a lab because of illness, family difficulties, or other legitimate reasons, please let me know in advance (whenever possible) so we can arrange for a make-up time.

You will receive a grade for each of the formal lab reports. These grades, along with an evaluation of your lab notebook (which will be weighted like one formal lab report) and an overall evaluation of your performance during the labs will constitute your lab contribution for the course grade.

Intellectual Responsibility

Discussion and cooperation between lab partners is strongly encouraged and, indeed, often essential during the lab sessions. However, each student must keep a separate record of the data and must do all calculations independently. In addition, laboratory partners are expected to share equally in the collection of data.

The use of any data or calculations other than one's own, or the modeling of discussion or analysis after that found in another student's report, is considered a violation of the statement of intellectual responsibility. We wish to emphasize that intellectual responsibility in lab work extends beyond simply not copying someone else's work to include the notion of scientific integrity, i.e., "respect for the data." By this we mean you should not alter, "fudge," or make up data just to have your results agree with some predetermined notions. Analysis of the data may occasionally cause you to question the validity of those data. It is always best to admit that your results do not turn out the way you had anticipated and to try to understand what went wrong. You should NEVER ERASE data that appear to be wrong. In fact, it's better for you to use ink for lab notebooks anyway. It is perfectly legitimate to state that you are going to ignore some data in your final analysis if you have a justifiable reason to suspect a particular observation or calculation.

Comments on Formal Laboratory Reports

The formal lab report should be a complete (though concise) presentation of your work on this experiment. It will be due at the beginning of the *following* laboratory session. It should be written for someone who has a physics background equivalent to Physics 17, but who does not know anything about the lab and the measurements you carried out. If we find that the report could be substantially improved by rewriting, we will ask for a revised report before a grade is given for the lab. Whenever possible, use a word processor for your report to simplify any revising and editing that need to be done after the first draft.

The report should include the following:

- Title: Also include your name, the data, and the name(s) of your partner(s).
- Introduction: What is the purpose, the main goal, of the experiment, and why is the experiment a worthwhile means of exploring a particular physical concept?
- Theoretical background: What the theory predicts, what assumptions have been made, and how the experiment relates to the theory for the physics being studied. Define the quantities to be determined and how they are related to the directly measured quantities.
- Experimental technique: What was measured and how was it measured? You need not describe every detail of the apparatus unless the details are crucial to your experiment or are modified from the “standard” apparatus for the lab. If you employ any special techniques in reading the instruments, aligning the apparatus, starting and stopping stopwatches, etc., make sure to record it and report it. Include a simple sketch of the apparatus whenever possible. Indicate the primary sources of measurement uncertainty.
- Data, analysis, and results: Display the data clearly in one or more appropriate forms (tables, graphs, etc.). Describe how the final results are obtained and show a sample calculation where appropriate. Give estimates of uncertainties associated with each directly measured quantity. Be sure to include some discussion of experimental uncertainties and how those uncertainties affect the evaluation of your results.
- Discussion of results and Conclusion: Was the goal of the experiment accomplished? Were theoretical expectations satisfied within the range of uncertainty? What are the implications of your results?

Lab 1

Electrostatics

1.1 Introduction

This lab is really a brief menu of experiments designed to get you thinking about the properties of charged objects and their interactions with other objects, both charged and uncharged. Since another goal is to become familiar with working in the laboratory, this is not meant to be particularly strenuous. Have fun! Pay close attention, though, and you may be surprised by some of the things you see.

1.2 Tape Electrometer

The equipment for this lab is remarkably simple: two roughly 3 cm long pieces of transparent tape. Fold a little bit of the ends of the tapes over themselves to make a little “handle” that won’t stick to things. This will make it easier to pull the tapes apart and off of surfaces.

In addition, you will need some insulators to rub and some materials to rub them with, and a few assorted objects such as magnets and paper clips. I will provide some of these things; others you may be carrying around as everyday items in your backpacks.

1.2.1 Preparing the Tapes

On one of the two tapes mark the letter “B” (for Bottom) and, on the other, the letter “T” (for Top). Stick the two tapes together, sticky-side of tape “T” on the non-sticky side of tape “B.” Then, holding the tapes by their handles, pull them apart quickly. (Try not to touch the tapes excessively with your fingers, or anything else.)

What do you observe when you bring the tapes near one another? Does the effect change if you allow the tapes to touch one another? If so, how?

1.2.2 An Electrometer

Prepare the tapes again in the usual way. This time, stick them (carefully!) at the edge of a table, so that they are sticking out horizontally (i.e., parallel to the table surface). Try rubbing an insulating (that is, nonmetal) object, such as your plastic pen, with the fabric of your clothing. Bring the object up to the tapes (again, be careful not to touch unintentionally). What is the effect of the object on the tapes?

What happens if you bring instead the rubbing object, e.g., your clothing, near the tapes?

Repeat this experiment several times with different combinations of rubbing and rubbed objects. What patterns emerge from your data?

If you are careful about handling the tapes you can bring them near charged objects rather than the other way around. You can try this in the other experiments described below.

1.2.3 Which is Negatively Charged?

We have called the tapes “T” and “B,” which is a perfectly fine convention for their charges. If we want to communicate with physicists elsewhere, however, we might want to use a slightly more standard convention and call them “positive” and “negative,” or “+” and “-.” Ben Franklin chose to call the charge on a glass rod after it had been rubbed with silk “positive,” and the charge on a rubber rod after rubbing it with fur “negative.” Armed with this knowledge, can you figure out which of your tapes is positive and which is negative? Compare with others in the class after making your decision and recording it indelibly in your lab notebook.

1.3 Versorium

There are two Versoria you can build: a metal one and a wood one. Explain how each one works (they are slightly different).

1.4 Electrophorus

See an instructor for use of the electrophorus. Does the metal plate become positively or negatively charged?

1.5 Wimshurst Machines

BE VERY CAREFUL with the Wimshurst machines — they are quite fragile and can deliver a momentarily painful electric shock. Turn the crank in the direction indicated by the arrows on the machine chassis. If the belt slips off or the “teeth” start scraping the wheels contact an instructor. Discharge the machine before attaching or removing wires.

The Wimshurst machine separates charges by induction. Can you figure out which terminal is positive and which terminal is negative?

See if you can figure out how the Wimshurst machine works. (Keep it as conceptually simple as possible.) We'll discuss it at the end of lab today.

1.5.1 Franklin's Bells

Consider the following passage, from Walter Isaacson's recent biography Benjamin Franklin: An American Life (Simon & Schuster, New York, 2003) p.143:

That September, [Franklin] also erected a [lightning] rod on his own house with an ingenious device to warn of the approaching of a storm. The rod, which he described in a letter to [his friend] Collinson, was grounded by a wire connected to the pump of a well, but he left a six-inch gap in the wire as it passed by his bedroom door. In the gap were a ball and two bells that would ring when a storm cloud electrified the rod.

Re-create Franklin's alarm system, using a suspended pith ball and a pair of plates, one of which you connect to each terminal of a Wimshurst machine (to represent the Earth and an electrical storm, respectively). Explain, using appropriate diagrams and descriptions, how Franklin's storm-warning system worked. Focus in particular on why the ball alternately strikes one bell and then the other when a charged storm cloud is overhead.

1.5.2 Spinning Structures

If you hook up one of the “spinners” to a terminal of the Wimshurst machine you will find that it begins to rotate. Why? Does it matter which terminal you attach it to?

1.6 Van de Graaf Generator

CAUTION: The Van de Graaf can deliver a momentarily painful shock.

Does the dome of the Van de Graaf generator become positively or negatively charged? See if you can figure out how it works. We'll discuss it at the end of lab today.

1.7 Kelvin Water Dropper

Pour water in the top of the Kelvin water dropper. (Try not to get water everywhere.) Which side becomes positively charged, and which side negatively charged? Does it change each time you run the experiment? Can you force it to go one way rather than the other? See if you can figure out how it works. Does anything happen to the water streams when the machine becomes charged?

1.8 Conclusions

Let's see if we can finish up by 4:30 this afternoon, at which point we can gather for discussion of how the electrostatic generators work.

Lab 2

DC Circuits

2.1 Background

In this lab you will be causing electric charge to flow through a variety of materials. This flow of charge will not be covered in lecture for several more weeks. In lab, therefore, we will be taking a less formal, more phenomenological point of view.

The motion of charge is called an electric current in analogy to the flow of fluid. Consider the flow of a fluid, like water, through a pipe (Fig. 2.1). The current through this pipe is

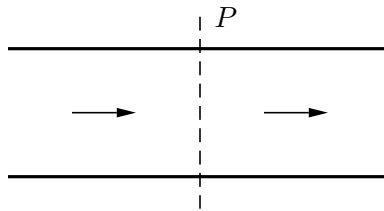

Figure 2.1. Flow of fluid across a plane P .

characterized by the amount of fluid, measured by volume flowing past a plane P which is perpendicular to the pipe, per unit time. Similarly, if charge is flowing through a wire the electrical current is characterized by the amount of charge flowing through P per unit time. The symbol for electric current is I and its units are

units of electric current are amperes (amps, A)
1 ampere = 1 C/s = 1 A

To get water to flow through a pipe there must be a pressure difference between one end

and the other. The analogous concept with electrical circuits is potential difference. The symbol for electric potential difference is V , and its units are

| |
|---|
| units of electric potential are volts (V) $1 \text{ volt} = 1 \text{ J/C} = 1 \text{ V}$ |
|---|

Hooking both ends of a hose up to the inlet and outlet of a water pump will cause water to flow through the hose. A battery plays a similar role for electric circuits. Attaching one end of a wire to the positive end of a battery and the other to the negative end will cause charge to flow through the wire. (Please take my word for this and refrain from discharging the batteries in this way.) Batteries are special kinds of electrical pumps because they pretty much always maintain the same potential difference between the positive and negative ends no matter what the current.

The ratio between the potential difference between say the ends of a wire and the electric current flowing through the wire is called the resistance, R , of the wire

$$R = \frac{V}{I} \tag{2.1}$$

The units of resistance are

| |
|---|
| units of resistance are ohms (Ω) $1 \text{ ohm} = 1 \text{ V/A} = 1 \Omega$ |
|---|

Devices for which R is a constant are said to be **ohmic**.

| |
|-------------------|
| Ohm's Law: |
|-------------------|

| |
|----------|
| $V = IR$ |
|----------|

| |
|-----------------------|
| $R = \text{constant}$ |
|-----------------------|

Devices that obey Ohm's Law are called resistors.

Because electrical circuits can get enormously complicated, an elaborate system of symbols has been developed to help us draw the circuits we study. A battery, for instance, is represented by the symbols in Fig. 2.2. The longer vertical line indicates the position of the positive end of the battery.

A resistor is represented by the drawing in Fig. 2.3.



Figure 2.2. A simple cell (left) and battery (right).



Figure 2.3. A resistor.

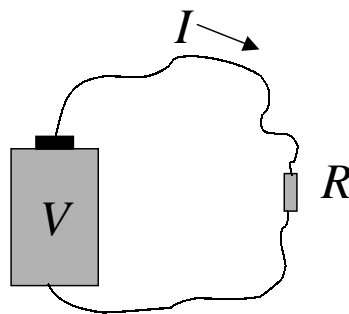

Figure 2.4. A “real” circuit with battery and resistor.

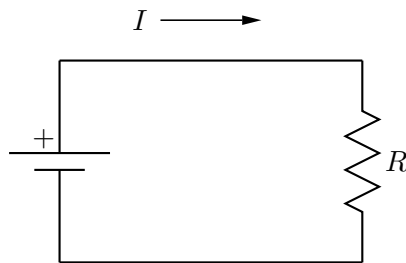

Figure 2.5. A simple circuit diagram.

A circuit which in “reality” looks something like that shown in Fig. 2.4 is represented symbolically like that shown in Fig. 2.5. Current, by definition, flows out the positive end of the battery as shown.

To measure electric current we use a device called an ammeter, which is represented symbolically in Fig. 2.6. Current must flow *through* an ammeter (Fig. 2.7). The ammeter will display the current that flows into its “red” lead and out of its “black” lead. If the measured current is negative, then the current is actually flowing into the black lead and out of the red lead. Sometimes these meter leads are referred to as “positive” (red) and

“negative” (black) — for now, let’s agree to eschew this convention, which often brings with it unnecessary confusion.

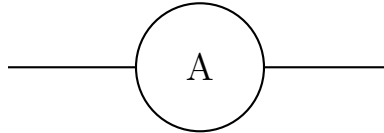

Figure 2.6. The ammeter.

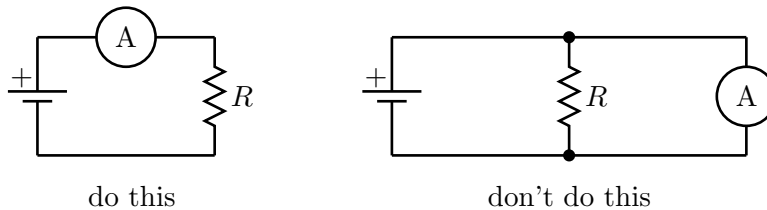

Figure 2.7. Use the setup on the left, not the right, for an ammeter.

To measure electric potential differences we use a two-terminal device called a voltmeter, represented symbolically in Fig. 2.8. Voltmeters measure the potential *difference* between (or *across*) points a and b , i.e., if the potential is V_a at point a and V_b at point b , the voltmeter will display $V_a - V_b$. As with the ammeter, there is a “red” (a) and a “black” lead (b) — the price you pay for confusing these two leads is an extra minus sign the voltage displayed by the meter. Please note that you should not set up your circuit to require current to flow through a voltmeter (Fig. 2.9).

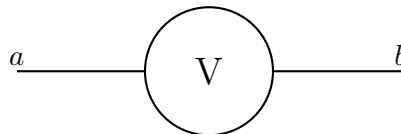

Figure 2.8. The voltmeter.

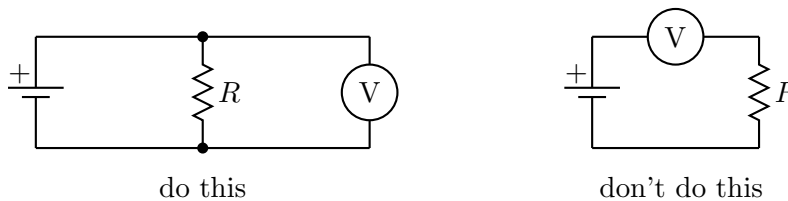

Figure 2.9. Hook up a voltmeter as shown on the left, not as shown on the right.

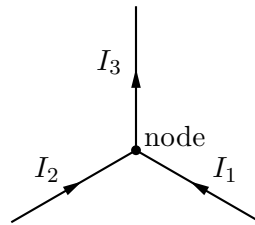

Figure 2.10. Conservation of charge (current) at a junction of several wires.

2.1.1 Kirchhoff's Rules

Kirchhoff's name is associated with two laws. The first, **Kirchhoff's current rule**, expresses a property of charge, namely, that it is locally conserved:

“The sum of all currents into a junction is equal to the sum of all currents out of the junction.”

If we have a junction into which the currents I_1 and I_2 flow, and out of which I_3 flows, then we know by Kirchhoff's current rule that

$$I_3 = I_1 + I_2. \quad (2.2)$$

If this weren't the case, then charge would build up at the junction! After a while we'd know if that were happening.

The second of Kirchhoff's rules, **Kirchhoff's voltage rule**, expresses conservation of energy in the circuit.

“The sum of all voltages around any circuit loop must be zero.”

A formal proof of Kirchhoff's voltage rule will have to wait a little while. You can think of it in terms of the conservation of energy of water that is pumped up through a water pipe and flows back down to ground level. At the end of its journey it has the same potential energy it had when it started. The journey of a unit of charge through a circuit is similar—in steady state, it must also have the same amount of energy (*i.e.*, be at the same voltage) upon completing a loop and coming back to its starting point in the circuit.

2.1.2 Resistors in Series and in Parallel

Back in Lab 2, you used a circuit in which you measured current through and voltage across several “unknown” devices (red, white and blue) in order to determine which were ohmic,

and for those that were, what their resistance was. You also determined the equivalent resistances when the ohmic devices were connected in series and in parallel.

Recall that resistors R_1 and R_2 connected in series add according to the equation $R = R_1 + R_2$, where R is the effective resistance of the combination. For resistors R_1 and R_2 in parallel, the effective resistance is given by $1/R = 1/R_1 + 1/R_2$. In order to see why resistances add according to the rules described above, we must examine Kirchhoff's laws.

We will often encounter two resistors in series, as shown in Fig. 2.11. (We say that the resistors are in series because the current has no choice of path — if it flows through one resistor, it must serially flow through the other.) Later we will show that this new device behaves exactly like a resistor with an effective resistance $R = R_1 + R_2$. Notice that R is always greater than R_1 or R_2 . Because wires typically have a small resistance they can usually be ignored because of this rule.

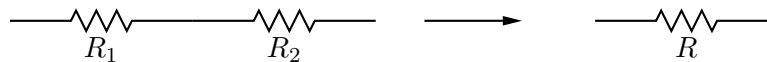

Figure 2.11. Two resistors in series behave as a single resistance $R = R_1 + R_2$.

The other way to hook up two resistors is “in parallel,” as shown in Fig. 2.12. In this case the current will divide itself up among the various paths — two, in this case. We will show later that the two resistors together behave as a single resistor of resistance R , where $R^{-1} = R_1^{-1} + R_2^{-1}$. In this case, R will always be less than both R_1 and R_2 .

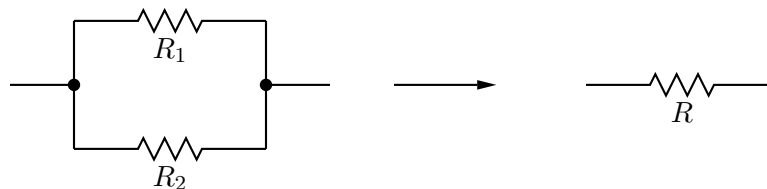

Figure 2.12. Two resistors in parallel behave as a single resistor of resistance $R^{-1} = R_1^{-1} + R_2^{-1}$.

2.2 Ohm's Law

2.2.1 Equipment

You will be given the following:

1. A breadboard made of white plastic on a black metal plate that permits easy connections to be made between wires, resistors, batteries, and so on. Use of the breadboard is easy to see but hard to explain in print and will therefore be explained in class.

2. A nominal 1.5 V cell. (The word “nominal” is a code word in physics that means “don’t trust that this is actually so until you have measured it,” i.e., *caveat emptor*.)
 3. A pair of digital multimeters.
 4. Two boxes of resistors.
 5. Two unknown resistors (red and white), and a small lamp.
- Hook-up wire will also be available.

2.2.2 Preliminaries

The multimeters can be used to measure several different things. The central knob has sections marked ‘DCV’ (voltmeter) and ‘DCA’ (ammeter) that will be useful for our work today. The various knob settings within a particular section have to do with the sensitivity of the meter, and denote the *largest* value that can be measured at that setting. [For example, setting the meter to read ‘DCV:200m’ means that the largest value that can be measured is 200 mV. To measure a voltage greater than 200 mV, such as 450 mV, one would have to turn the knob to the ‘DCV:2’ scale, which has a maximum range of 2 V. A larger voltage won’t hurt the meter, but it will probably read ‘-1’ by way of telling you that something is wrong.] Smaller numbers on the knob represent higher sensitivity, i.e., more digits of precision, but a reduced ability to measure larger values. This trade-off between range and precision is common with electronic instruments.

Conventionally one plugs a red lead into the ‘+’ terminal of the multimeter, and a black lead into the ‘-’ terminal.

Let’s start by measuring the voltage of a battery with a voltmeter. Connect (touch) the ‘+’ terminal of the battery to the red lead of the voltmeter, and the ‘-’ terminal of the battery to the black lead of the voltmeter. Adjust the voltmeter to get as sensitive a reading as you can, and record it in your lab notebook. Now reverse the leads of the voltmeter and repeat the measurement. Is there any difference? What do you conclude about using the voltmeter?

There are three “power supplies” on your breadboards, two of which can be used as a kind of “variable battery.” Try this now: measure the voltage between the red and black terminals of the power supply. You should measure 5 V. Now try another measurement between the yellow terminal and the black terminal. What happens when you adjust the knob labeled $V+$? Try this yet a third time for the blue and black terminals of the power supply, using the $V-$ knob.

Set the positive supply ($V+$) to +6 V. Connect one lead of the light bulb to the black terminal, and then connect the other lead of the light bulb to the yellow terminal of the power supply. What do you see?

“Build” the same circuit using the JAVA circuit simulator from the web site. Notice the flow of electrons when the circuit is completed.

To make an ammeter, turn the knob on the multimeter to the ‘DCA’ section and select the proper sensitivity. Be careful not to do this accidentally with a meter that already connected to a circuit as a voltmeter — the price will likely be a fuse within the ammeter, diagnosed as its frustrating inability to read or pass any current whatsoever.

Put the ammeter in the circuit in such a way that you can simultaneously measure the current through, and the voltage across, the device. Make the measurement as sensitive as you can by adjusting appropriately the range knobs on the voltmeter and ammeter. (You can also include an ammeter in the circuit simulation.) Try to hook it up in the breadboard neatly; you needn’t have wires dangling all over the place. It may help in particular to keep your two meters (and their leads) separate from one another.

2.2.3 The Experiment

Design a circuit that will help you determine whether your three unknown devices have current-voltage characteristics described by Ohm’s Law. Use your circuit to obtain about 10 (I,V) values for each device (red, white, lamp). Your laboratory notebook should contain a current-voltage graph for each of these devices.

IMPORTANT: Do not apply more than ± 6 V to (or, rather, *across*) the lamp, or it will burn out. I would recommend starting with the smallest variable voltage the breadboards can generate and then turning up the voltage carefully to something approaching 6 V to avoid this.

IMPORTANT: Be certain to check whether or not these (I,V) values depend upon the direction in which the current flows through the unknown — you’ll have to figure out how to reverse the direction of the current at some point so that you can get data for current going both directions. Reversing the meter leads does NOT reverse the direction of current through the device you are testing, but it does multiply your subsequent measurements by the factor -1 . (Hint: use the negative supply rather than the positive supply, so that you have to move as few wires and meter leads as possible. Make sure you are not applying more than $|-6V|$ before making any connections!)

Your graphs should have the origin somewhere in the middle of the sheet, so that an $I-V$ graph would look something like that shown in Fig. 2.13:

Determine the resistances of the Ohmic devices. Is the lamp Ohmic? If not, what can you say about it (e.g., at what point does the lamp begin to light up)?

Notes on Uncertainties: You will be measuring current and voltage, and there will be

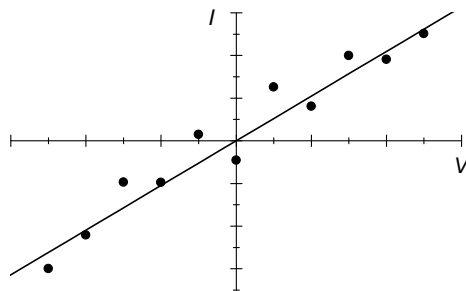

Figure 2.13. How your I - V graph might look. Yours will no doubt properly include error bars, however.

uncertainty associated with each of these. A composite uncertainty can be assigned as follows: if you have measurements $y \pm \delta y$ and $x \pm \delta x$, and for the purposes of assigning error to a linear fit you need just a single error bar on y (and none at all on x), then try the following. First, translate the error in x to an error in y ; the relationship here is linear, i.e., $y = mx$, so

$$\delta y' = m \delta x = \frac{y}{x} \delta x. \quad (2.3)$$

Your effective error bar in y is then the sum δy and $\delta y'$, in quadrature, or

$$\delta y_{\text{eff}} = \sqrt{(\delta y)^2 + (\delta y')^2}. \quad (2.4)$$

This is only for the linear fit (where appropriate). I would prefer that you put the error bars in both x and y on your plot.

You can take the statistical uncertainty to be the fluctuation in the last digit of the multimeter.

Additional Hint: You may find that there is a “gap” in the data between ± 1 V. See if you can find a way, using the tools before you, to apply voltages smaller in magnitude than 1 V to your devices.

2.2.4 Using the Voltmeter as an Ohmmeter

In addition to voltmeter and ammeter functions, the meters can also measure resistance directly by using an ohmmeter function. Go ahead and do this at the conclusion of the day’s activities (try not to spoil the excitement by doing it earlier). Comment on the values you measure in this way (and be sure to include meter uncertainties).

2.3 The Laboratory Report

Your formal laboratory report should include:

- diagrams of the circuits used,
- all data,
- graphs of the data. The graphs should be titled and axes should be labeled.
- results.

Your laboratory notebook should include these same things, perhaps in rougher form, and also:

- answers to the questions posed in this handout
- a summary of the day's activities.

See the Laboratory Information notes for further suggestions about writing lab reports.

Lab 3

Introduction to the Oscilloscope

The oscilloscope is one of the most powerful and versatile devices in the physicist's toolbox, capable of displaying voltage as a function of time. In today's experiment, you will become familiar with some of the common operations of an oscilloscope.

3.1 Comments

- It is impossible to damage one of these scopes by twiddling the knobs. So do not be inhibited — try things out and see what happens.
- These scopes may seem at first to have a bewildering array of knobs and switches. That is the price we pay for versatility. We will suggest some initial settings. As you learn to know and love these scopes, you will become more adventurous. If you get too adventurous too quickly and lose the beam altogether, first try (by thinking about the functions of the various controls) to get it back; if you fail, go back to the suggested initial settings. If that fails, an instructor may be able to help.

3.2 Front Panel

The diagram below is taken from the Tektronix instruction manual. The large numbers (1, 2, 3, ..., 33) refer to parts of the manual, and they can be ignored for now. Copies of the manual itself will be available in the lab. The notes attached here constitute a condensed instruction manual, enough to get anyone started, but you are welcome to look at the complete manual, either to get an idea of all the features that are available or to resolve possible ambiguities in our condensed version.

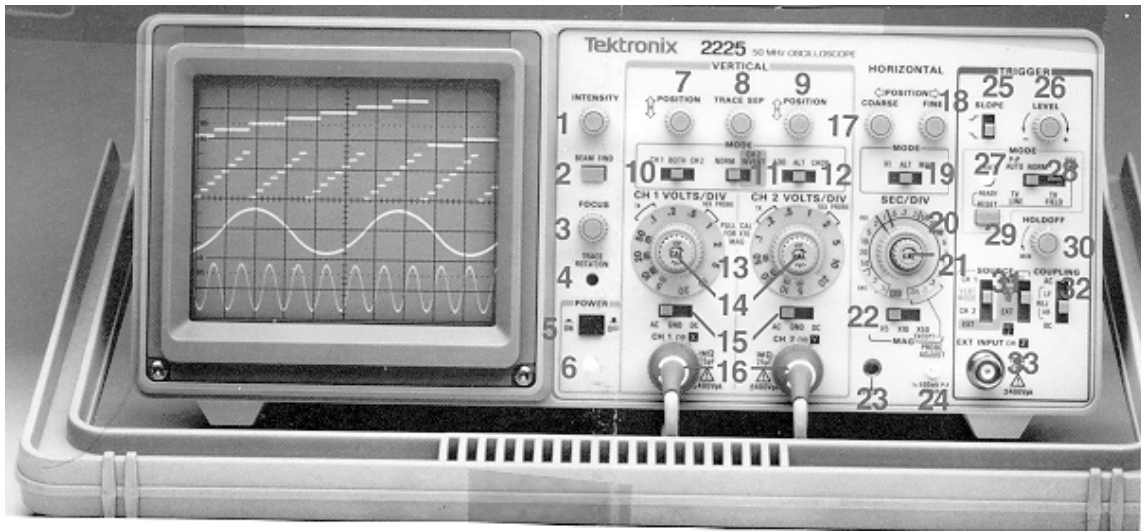

Figure 3.1. The Tektronix 2225 Scope.

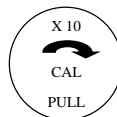

Figure 3.2. Voltage scale calibration knob (14).

3.3 Procedure

1. **Turn on the power.** After plugging in the power cord, push in the POWER button (5 on the diagram on the previous page). The green light just below it (6) should go on.
2. **Initial Settings.** Put the scope in its calibrated (CAL) settings. Most often, one wants to take advantage of the calibrated vertical deflection sensitivity and the calibrated timebase (the horizontal sweep speed). Rarely, if ever, does one put the scope on uncalibrated settings. So do the following:
 - (a) There are two small knobs labeled as shown in Fig. 3.2 (number 14 on the diagram). Push those two knobs in; then turn them fully clockwise until they click.
 - (b) There is one small knob labeled as shown in Fig. 3.3 (number 21 on the diagram). Turn it fully clockwise.
 - (c) Slide the “Horizontal Mode” switch (number 19 on the diagram) to the left ($\times 1$) position.
3. **Other initial settings.**

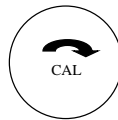

Figure 3.3. Timebase calibration knob (21).

- (a) CH 1 VOLTS/DIV (13) so that the “1” is next to “1×.” (Now the vertical deflection sensitivity is 1 volt/cm.) Do the same for the CH 2 VOLTS/DIV setting.
- (b) The switches just above that to CH1 (10), NORM (11), CHOP (12).
- (c) The switches just below the knobs (15) to the right (“DC”).
- (d) The Horizontal SEC/DIV switch (20) to XY.
- (e) The trigger MODE switch (27) to the left (“P-P AUTO”).
- (f) The trigger SOURCE switch (31) up (“CH 1”).
- (g) Focus the beam as narrowly as possible using the FOCUS knob.

At this point you should have a small bright dot on the oscilloscope screen. If you do not, try turning the INTENSITY control (1) further clockwise, or adjusting the POSITION control (7). If all else fails, ask one of the instructors. Then adjust the trace’s vertical position to be in the center of the screen.

4. Oscilloscope Vertical Deflection.

We now want to observe how voltages applied to the input of the oscilloscope result in a deflection of the trace vertically.

The connectors labeled (16) in the manual are called BNC connectors. Find two banana-to-BNC adapters and attach one to channel one of the scope and the other to channel two. Now connect a wire from one terminal of the D cell battery to the black connector of channel two’s input connector on the oscilloscope. Connect a second wire from the other terminal of the battery to the red post of channel one’s input connector on the oscilloscope. When you connect the second wire, the dot on the oscilloscope should deflect.

Use the amount of deflection and the VOLTS/DIV setting to determine the voltage produced by the battery. Is your result consistent with what you expect for a D cell battery? You can check this value against the value you read with a voltmeter.

Now reverse the two leads to the power supply and repeat the experiment. How does the oscilloscope trace deflect? Try hooking up the leads to CH1 and repeat the experiment once (or twice) more. What happens?

5. Ground.

The wire you have connected to the black banana plug terminal on the oscilloscope is connected to the planet through the power cable that is plugged into the wall outlet.

Customarily this “ground” connection is considered to be 0 V. As you know, this is a matter of convention, and we could assign any other value we like to it.

The protoboards we use are also connected to the ground through their power cable. This means there is an implicit connection at all times between the black terminals of the banana plug adapters on the oscilloscope and the black banana plug on the protoboard; that is, it is as if there is a wire always connected between those points. You cannot make that wire go away. Question: how does this restrict your ability to do measurements with the oscilloscope? Hint: what would happen if you connected the black terminal of the oscilloscope to, say, the blue, red, or yellow terminals of the protoboard? (Please don’t do this!)

Each channel of the oscilloscope therefore measures voltages on its red terminal with respect to ground (the black terminal). If you have a device or circuit that is in no way connected to the ground, such as the battery you used earlier, then the oscilloscope ground is not a big deal and the oscilloscope behaves just as our voltmeters did in the previous lab. On the other hand, if the circuit is connected to the ground somewhere, then you have to be careful about how you measure voltages with an oscilloscope. If in doubt, draw a circuit diagram in which you show the implicit ground connection explicitly.

6. Differential Measurements.

One can recover the good features of a voltmeter in a circuit that has a ground connection by doing a *differential* voltage measurement; in this measurement you display the voltage difference between channels 1 and 2. To do this kind of measurement, you attach leads to the two red banana terminals of the oscilloscope, turn the switches to BOTH (10), CH2INV (11), and ADD (12).

Try using the oscilloscope in this mode to measure the voltage of the positive voltage supply. Reverse the leads and see that it works as you might expect.

Although you can now measure voltages differentially, without worrying too much about the ground connection, your scope is effectively only a single channel. Another electronic trade-off!

7. Comparing Voltage Measuring Devices.

In this part we use the scope as a voltmeter and compare its readings to those of a digital voltmeter.

Set up a circuit to verify that resistors in series add like $R = R_1 + R_2$. Your circuit might have look like that in Fig. 3.4. (You can use the voltage across the $10\ \Omega$ resistor, and Ohm’s law, to measure the current.)

Now connect the digital multimeter (set to measure DCV) in parallel with the input of the oscilloscope, as shown in Fig. 3.5.

Use the pair of “leads” to the oscilloscope input to measure the voltage difference across various elements of the circuit. Pay attention to polarity. Vary the applied voltage and measure the voltage across each device using the oscilloscope. Verify that $R = R_1 + R_2$.

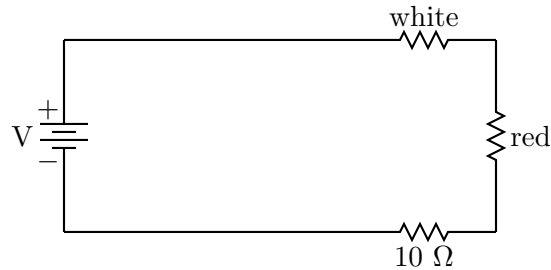

Figure 3.4. Circuit for measuring resistances in series.

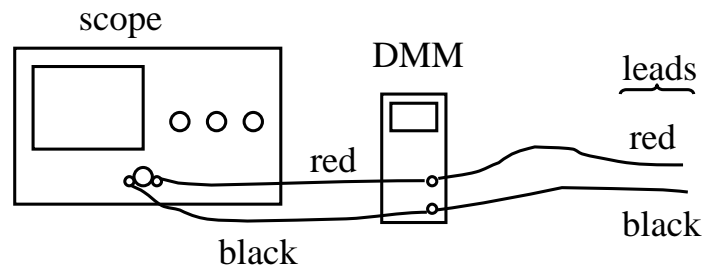

Figure 3.5. Hooking up the scope and digital multimeter in parallel.

8. Horizontal Time Sweep.

At this stage the oscilloscope is no more useful to us than a digital multimeter. The real power of an oscilloscope comes when we allow the oscilloscope to control the horizontal voltage for us.

Put the scope back in its two-channel settings (switches 10–12 should be CH1, NORM, and CHOP, respectively). You will use just CH1 for a while; if you want to use both channels separately, set switch 10 to BOTH, and if you want to return to the differential measurement mode set switches 10–12 to BOTH, CH2INV, and ADD, respectively.)

Set the SEC/DIV switch to 0.5 sec. You should now see a dot slowly scanning horizontally across the screen. Use a stop watch to time how long it takes to go all the way across the screen. Is your result consistent with the 0.5 sec/div switch setting?

9. A Rapidly Varying Voltage.

We will now use the built-in function generator of our protoboards to produce a rapidly-varying signal for the oscilloscope. The signal appears on the white connector on the left side of the protoboard and is adjusted with the sliders and switches near the connector.

Connect the oscilloscope to the protoboard function generator and set the function generator to generate a roughly 1 kHz sine wave. (Your instructors will be able to help you do this if you get stuck or are confused by the protoboard controls.)

Set the oscilloscope's SEC/DIV control to 1 msec. You will probably see a sinusoidal

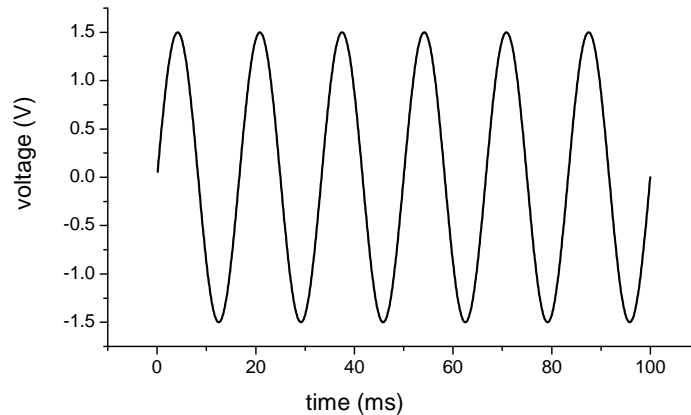

Figure 3.6. The 60 Hz sine wave.

waveform on the scope. If not, adjust INTENSITY, FOCUS and POSITION controls until you do.

When you have a sinusoid, experiment with various knobs to see what happens: SEC/DIV, INTENSITY, BEAM FIND, vertical and horizontal POSITION controls, and vertical sensitivity (CH 1 VOLTS/DIV), trigger SLOPE and trigger LEVEL. Explain to your lab partner what happens with each change of controls. In particular, make sure you understand what trigger SLOPE and trigger LEVEL do.

Does the scope correctly tell you that the sinusoid you are observing has a frequency of about 1 kHz?

From these exercises we learn that the oscilloscope can give us a visual display of a voltage that varies rapidly in time.

10. Square Waves and Triangle Waves.

Replace the frequency generator's sinusoidal output with its square-wave output and see what you get on the oscilloscope screen. Also vary the frequency setting of the frequency generator. Then try the triangle wave output.

11. Yet another time-varying signal.

Connect the output voltage of one of our small aluminum boxes to the Channel-1 input. With the knob on the aluminum box at its maximum setting, that voltage is supposed to be a sinusoid with a frequency of 60 Hz and a “peak-to-peak” size of about 3 volts, as shown in Fig. 3.6.

Are the size and frequency about right? You will have to reactivate the sawtooth sweep, i.e., the horizontal time-base. (That's an amplitude of 1.5 V, by the way; if you write the voltage as $V(t) = A \sin(2\pi ft)$, then $A = 1.5$ volts.)

12. A Mysterious Signal.

Now disconnect the aluminum box from the oscilloscope. Connect one wire to the red post on the oscilloscope input. Hold the other end of the wire in your hand. Adjust

the CH1 VOLTS/DIV control until you see a large signal on the screen. Where is this signal coming from? (Hint: what is the frequency of the signal?) Now connect another wire to the black input post and hold one wire in one hand and one wire in the other. What happens to the oscilloscope signal? Try to explain what is going on.

13. Artistic Lissajous Figures.

Reconnect the 60 Hz box to the Channel-1 input, connect the sinusoidal output of the function generator to the Channel-2 input, and put the HORIZONTAL SEC/DIV switch on “X-Y.” Now the scope’s time base is out of action again. The x -deflection is controlled by the voltage applied to Channel 1, the y -deflection by that applied to Channel 2.

Now observe Lissajous figures produced by the oscillator and the 60 Hz x -axis voltage, for various oscillator frequencies below 300 Hz. Can you explain the patterns you see?

Make a sketch in your notebook of the patterns you observe for $f_x = 60$ Hz and $f_y = 30, 60, 120, 240$ Hz.

By the way, look at the “Romer Art Machine” in the hallway, and the “operating instructions” that are posted nearby. How can you make a “fish” on the Art Machine? On the scope?

14. More fun with the oscilloscope.

There will be at least one digital scope connected to a microphone. The digital scope allows one to store a scope trace in the computer directly. Try recording your voice or various sounds, like that of a tuning fork.

3.4 Checking Out

For this informal lab no further write-up is required. Please write answers to the embedded questions in this handout in your lab notebook and a brief conclusion.

Lab 4

Capacitors

4.1 Summary

There are some involved and important discussions about theory and practice in the following pages — hence this summary.

1. You will look at the theory of resistor-capacitor (RC) circuits.
2. You will measure (indirectly) the resistance of a meter and your body.
3. You will determine the output resistance of the function generator.

Every real emf source has some internal resistance, which in many cases can have an important effect on its operation. Here we shall explore a simple but effective method of measuring that internal resistance to illustrate some basic notions about electrical circuits and about measurement philosophy. This is not just an “incidental” part of this lab!

4. You will observe an RC transient decay of a charged capacitor with external resistances of 1000 and 100 ohms.

4.2 Theory

Charging and discharging a capacitor through a resistor.

Consider the following circuit consisting of an emf source $V(t)$, a resistor R and a capacitor C connected in series.

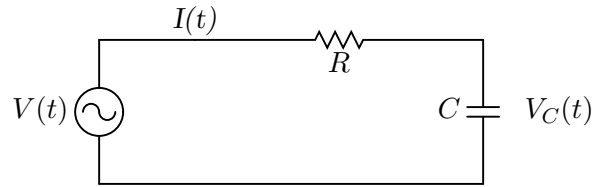

Applying Kirchhoff's Voltage Law to the circuit gives us the following equation:

$$V(t) = I(t)R + V_C(t) = \frac{dQ}{dt}R + \frac{1}{C}Q(t) \quad (4.1)$$

where we have made use of the relationship between the potential difference across the capacitor $V_C(t)$ and the charge $Q(t)$ stored on one of the capacitor plates. Dividing through by R gives a differential equation for the charge $Q(t)$:

$$\frac{dQ}{dt} = \frac{V(t)}{R} - \frac{1}{RC}Q \quad (4.2)$$

We will be studying two different types of behavior described by this equation.

4.2.1 Step Changes in the emf $V(t)$:

For the first type of behavior, we will have an emf source that jumps very quickly between two voltage values: one we call V_0 ; the other value will be taken to be 0.

Now let's consider the following scenario. Suppose that the emf value has been 0 for a long time. (What "long" means will become apparent in a moment.) Then we know that the capacitor will be completely discharged. Next, let's assume that the emf value suddenly jumps to the value V_0 and stays at that value. Let's call the time at which that jump occurs $t = 0$. In the differential equation for $Q(t)$, we treat the emf value as a constant, and the solution of the differential equation with the initial condition that $Q(t = 0) = 0$ (since the capacitor is initially completely discharged) is

$$Q(t) = V_0C \left(1 - e^{-\frac{t}{RC}} \right) \quad (4.3)$$

Exercise 1. Verify that Eq. 4.3 provides a solution of the differential Eq. 4.2 when $V(t) = V_0$ by evaluating the derivative of Eq. 4.3 and substituting the result and $V(t)$ into the differential equation to verify that the correct equality holds.

AN IMPORTANT BIT OF JARGON: Note that the product RC determines the time scale required for the capacitor to charge. This product is called the time constant for the circuit: $\tau_c \equiv RC$.

Unfortunately, we cannot measure the charge stored in the capacitor directly, but we can measure the potential difference across the capacitor (say, with the oscilloscope). The electrical potential across the capacitor is given by

$$V_C(t) = \frac{Q(t)}{C} = V_0 \left(1 - e^{-t/RC}\right) \quad (4.4)$$

Exercise 2. Using Eq. 4.4, draw a graph of $V_C(t)$ as a function of t .

Now suppose that the capacitor is completely charged. (The potential difference across it is equal to V_0 .) Then suddenly the emf potential drops back to 0. Let's reset our time axis so that this new drop occurs at a new $t = 0$. In this case, the charge stored in the capacitor and the potential across the capacitor begin to decrease with time:

$$Q(t) = V_0 C e^{-\frac{t}{RC}} \quad (4.5)$$

$$V_C(t) = V_0 e^{-\frac{t}{RC}} \quad (4.6)$$

Note once again that the product RC sets the time scale for the capacitor to discharge.

Exercise 3. Using Eq. 4.6, sketch a graph of the electrical potential across the capacitor as a function of time.

4.3 Measurement of the resistance of a meter.

There is only one setup for this part. You do not have to do this first. But do it!

Over at the side of the lab we have the following:

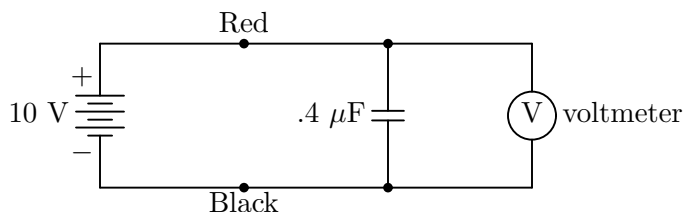

Initially, the voltmeter should read about 10 volts; call this value V_0 . Now break the circuit by disconnecting the red wire from the red terminal of the power supply. Observe how long it takes the meter reading to decrease to $0.37 V_0$. ($e^{-1} = 0.37$. Look at Eq. 4.6 to see why we use this value.) Give numbers (in ohms) for the meter's resistance. (Don't worry about precision — rough values are OK here.)

4.4 Measuring the “internal resistance” of the function generator.

TERMINOLOGY: sometimes we will call this quantity r the “output resistance” of the function generator, and sometimes, as a variant (the reason for which is not now obvious), the “output impedance.” (The latter is the most common jargon among physicists and engineers.)

It should be fairly obvious that we cannot measure the internal resistance of an emf source by using an ohmmeter. (If it is not obvious, discuss this point with your lab partner.) However, by making some clever voltage measurements, we can determine r rather easily.

Parenthetical note — We need a voltmeter that can measure a potential difference without appreciably altering that potential difference. In fact, we can do it using any voltmeter of “very high” resistance, i.e., one whose resistance is very high compared to the other resistances in the circuit. In this lab, our scope plays this role; its resistance is about 10^6 ohms (1 Megohm). (That is plenty large enough to be effectively “infinite” in this lab; there might well be other situations in which 1 Megohm is not “infinite.”)

Consider this circuit:

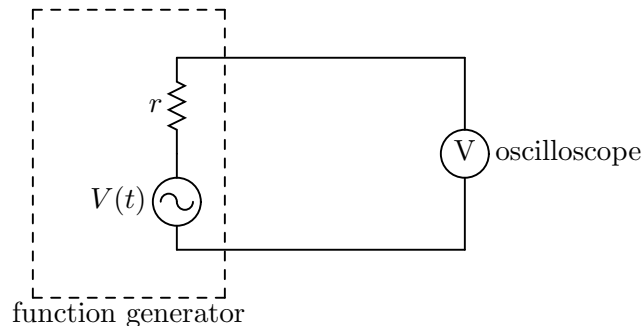

where r denotes the internal resistance of the function generator.

Now look at this circuit:

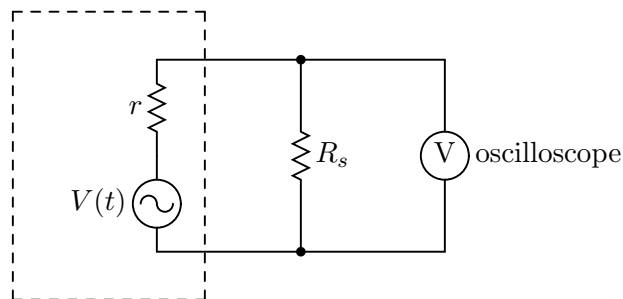

Set up the function generator to produce square waves with a frequency of 400 Hz. Set the

function generator VOLTS OUT in the “out” position (“0–20 V P-P”). (The two buttons next to it should also be “out.”)

The square-wave voltage seen on the scope will be smaller in the second circuit than in the first. Suppose that you adjust R_s so that the observed voltage (amplitude) in the second circuit is half what it is in the first. Use that idea to find r . For R_s , use a multiturn 1 k resistor. We will need this value of r for the other measurements in this lab.

4.5 RC Response to a step change in emf.

We wish to verify that the equations developed in Section 4.2 describe the response of an RC circuit to step changes in the applied emf. We will then use that response to determine the capacitance of the capacitor from measurements of the time constant, RC , of the circuit.

For a circuit with a large time constant (i.e., a minute or more) it would be possible to study the charge and discharge processes by placing an ordinary high resistance voltmeter across the capacitor and reading the potential difference every few seconds. Alternatively, the vertical input to an oscilloscope might be connected across the capacitor.

The time constants of the circuits you are provided with, however, are only a fraction of a second and the methods described above are inadequate. (A “one shot” oscilloscope, whose horizontal sweep can be “triggered” — i.e., the horizontal sweep initiated — by the throwing of the switch, and which has a long persistence screen, could be used. A short persistence screen also would be satisfactory if the trace on the screen were photographed or if the information were stored digitally.) The technique we shall employ consists of arranging to have the capacitor go through a series of identical charges and discharges in a periodic fashion. If the linear horizontal sweep frequency is adjusted so that the spot moves once from left to right each time the capacitor is charged and discharged, the successive curves will be superposed on each other as though one cycle were being observed, and measurements can be made on the steady continuous display.

The periodic charging and discharging of the capacitor could be achieved by using a battery and motor-driven switch which made the appropriate connections alternatively at regular intervals. The function generator is a more convenient device. When set for a “square wave” output, the function generator is designed so that it acts like a battery with an emf that is alternately zero and $+V_0$, switching back and forth between these two values at a rate controlled by the frequency setting on the function generator. If, for instance, the frequency is 500 Hz, then for 1 millisecond the function generator acts like the circuit on the left in the figure below. Then for the next millisecond, it acts like the one on the right:

The size of V_0 can be adjusted with the amplitude control on the function generator. Note also that this “battery” has an internal resistance, denoted here by r , which will have to be taken into account.

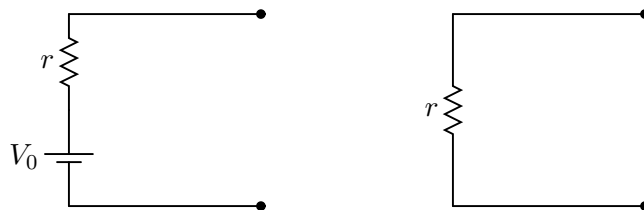

Connect the circuit as shown in below, which is essentially the same as the circuit shown on page 4.2 except that the emf source is replaced by the function generator. NOTE: The ground terminal of the output of the function generator must be connected to the ground terminal of the oscilloscope. For C , use a nominal “0.1 μF ” capacitor, and *record* its i.d. number.

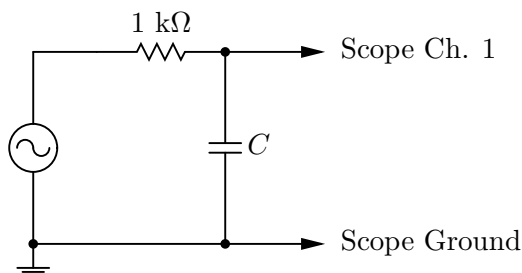

Set the function generator to produce a large amplitude square wave at about 400 Hz to begin with. Observe the waveform, then increase and decrease the frequency by a lot and just look at what happens. (Adjust scope time base and vertical sensitivity as desired.)

Then set the function generator at a convenient frequency at which you can see an almost total decay of one of the exponential curves, but sufficiently spread out so that you can measure it. We recommend using the VERTICAL POSITION knob to put the level which the exponential decay is approaching on the bottom line of the screen.

Measure $V_C(t)$ as a function of t for about 10 values of t . [Remember — your raw data for both V_C and t are in centimeters; do not forget to note oscilloscope VOLTS/DIV and SEC/DIV settings.]

IMPORTANT — Now change the 1 k Ω resistor shown above to a 100 Ω resistor, and repeat your measurement.

4.6 Analysis.

Analyze and graph at least one of the decays of the sort just described before leaving the lab. Show your graph and your results to one of the instructors.

The theory developed in Section 4.2 says that the voltage across the capacitor is of the

form:

$$V_C(t) = Ae^{-t/RC} \quad (4.7)$$

where A is some constant.

Use a spreadsheet program to plot the data with error bars and to find the best fit that you can. Then find C , remembering that R includes the “output impedance” of the function generator.

You have two values of C from the two sets of measurements with different values of R . If the two values are not in agreement (that is, within the combined experimental uncertainty), then something is wrong. Discuss the situation with your lab partner. Consult with the instructors.

What is your conclusion as to what C is?

$$C = \text{_____} \pm \text{_____}$$

In attaching uncertainties to the final result, probably the dominant source of uncertainty comes from the difficulty of reading voltages from the scope face and in choosing the best straight line for your graphs. We suggest that for present purposes you regard the resistors and the scope calibrations (seconds per division, etc.) as precisely accurate. (That is, uncertainties there probably make a very small contribution to the overall uncertainty).

FOR YOUR REPORT:

Include all graphs and arguments that lead you from graphs to values of C , etc.

Is it necessary to know the frequency of the square waves from the function generator?

Lab 5

Semiconductor Diodes

This lab is in part about semiconductor diodes, and some of the fun one can have with these drastically non-ohmic devices. But it also provides an excellent chance (if you think about what you are doing and seeing) to understand more deeply the nature of charge, current, and voltage.

5.1 Introduction

A diode¹ is a distinctly non-ohmic two-terminal device. When a voltage of one polarity is applied, it acts like an open circuit ($R = \infty$); in the language of electrical engineering, the diode is “reverse-biased.” With the opposite polarity applied, the diode acts like a wire ($R \sim 0$); in this case the diode is “forward-biased.” (Because it is so obviously a non-ohmic device, however, it is not really proper to use the symbol “ R ” at all in describing it.)

A better way of describing a two-terminal device is to give its “ I - V characteristic,” which for an ohmic resistor is a straight line through the origin, as shown in Fig. 5.1.

For an ideal diode, the I - V characteristic consists of two straight segments, as shown in Fig. 5.2.

For even a tiny forward bias voltage, any amount of current can pass; for a reverse-biased diode, the current is zero no matter how large the voltage.

Fig. 5.3 gives a better approximation to the I - V characteristic of a real diode. The diode

¹The term “diode” is used because the devices are made with two types of semiconductor materials (see the Supplementary Notes that follow this lab handout). Vacuum-tube diodes, which are much older devices, have two electrodes instead: an anode and a cathode.

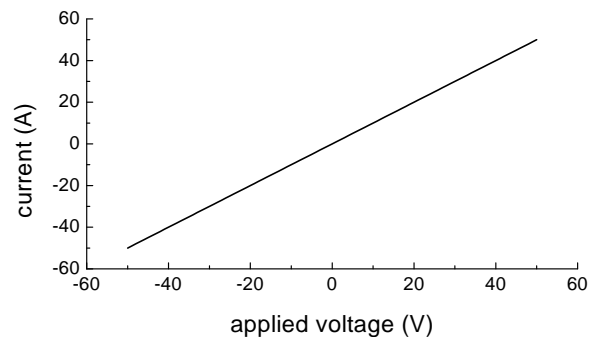

Figure 5.1. I - V curve for a resistor.

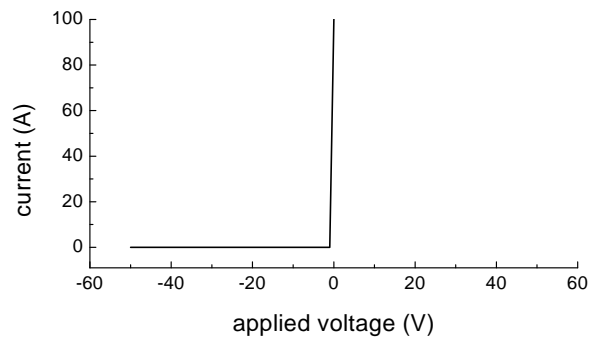

Figure 5.2. I - V curve for an ideal diode.

does not “turn on” until the forward bias gets up to about 0.6 V or so. In reality, the current when the diode is reverse-biased is not rigorously zero; but Fig. 5.3 is generally close enough to help us explain most of what we observe, and even Fig. 5.2 will often explain the salient features of our observations.

Why do diodes behave this way? How can we make such 2-terminal devices? Just as we did not explain why ohmic resistors act the way they do, we shall also adopt a phenomenological approach toward diodes. Accept them, see how they behave, and — given their I - V characteristics — understand their behavior in circuits. (Some attempt at explanation, however, is given in the Appendix to these lab notes.) The nonlinear behavior of diodes is what makes possible the whole range of modern electronic gadgets: DVD players, computers, televisions, radars, ballistic missiles, and so forth. Some diodes even produce light! They are called LEDs (for Light-Emitting Diodes).

The conventional circuit symbol for a diode is shown in Fig. 5.4. The arrow (triangle) indicates the direction of easy conduction of conventional current (as if positive charges flow). (The diode package itself usually has a small band etched or painted around it at one end; this is the end to which the arrow points.) In Fig. 5.5, the diode is forward biased, and a current of about 10^{-2} amps flows in the following circuit in the direction shown.

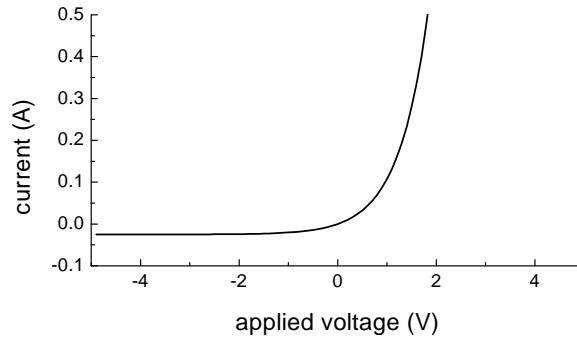

Figure 5.3. I - V curve for a real diode.

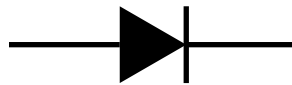

Figure 5.4. The schematic symbol for a diode.

The voltage across the diode is nearly 0 V (actually about 0.6 volts, see Fig. 5.3), and the voltage across the resistor is about 100 volts.

In Fig. 5.6, the diode is reverse-biased. There is a tiny current (no current if the reverse-biased diode does not conduct at all), the voltage across the diode is about 100 volts, and the voltage across the resistor is nearly 0 volts.

In this lab we want you to become familiar with some of the ways in which diodes can be used. Include in your notebook:

- Sketches of the waveforms seen on the oscilloscope for each of the circuit configurations described below.
- Brief explanations of why the circuits behave the way they do.

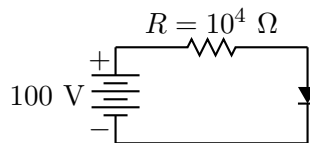

Figure 5.5.

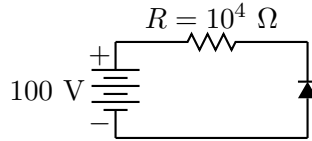

Figure 5.6.

5.2 Procedure

First, design and set up a circuit that will enable you to confirm the $I - V$ relationship for a diode. (Hint: you may want to make use of a variable external resistor.) Take 5–10 data points for each voltage polarity.

THEN, in the circuits shown below, we suggest that you simply leave the Function Generator terminals connected to Channel 1 on the scope. Use Channel 2 to observe the “more interesting” waveform.

IMPORTANT. Set the “CH1-BOTH-CH2” switch on “BOTH” so that you can observe the voltages applied to both channels 1 and 2 simultaneously. Set the scope on “DC” for both channels. (By temporarily putting an “AC-GND-DC” switch on “GND,” or “ground,” you can see where 0 volts is for either channel 1 or channel 2. Put the “ADD-ALT-CHOP” switch on “ALT.” Ask an instructor to explain the effect of any of these settings if you are confused.)

5.2.1 Half-Wave Rectifier

The half-wave rectifier circuit is widely used in all sorts of electronics, from computers to DVD players. As we shall see, with a slight modification given below, this circuit can be used to produce a DC (steady) voltage from an AC (alternating current) source, a necessity for most electronic components that receive their power from standard electrical outlets.

- Wire up the circuit shown below (Fig. 5.7). Set the Function Generator to produce its largest possible amplitude sine wave with a frequency of about 1 kHz.

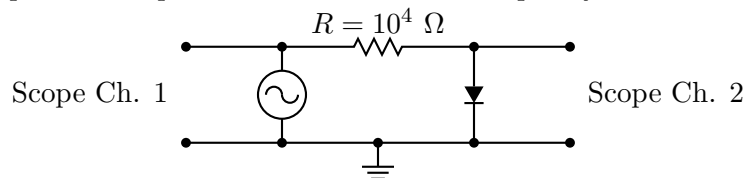

Figure 5.7.

- Observe the potential difference across the diode on CH2 of the oscilloscope. Record this waveform in your lab notebook and write a brief explanation of what is going on. Why is this circuit called a “half-wave rectifier”?
- Now reverse the diode in the circuit (Fig. 5.8). Again record what you see on the oscilloscope. Explain the circuit behavior.

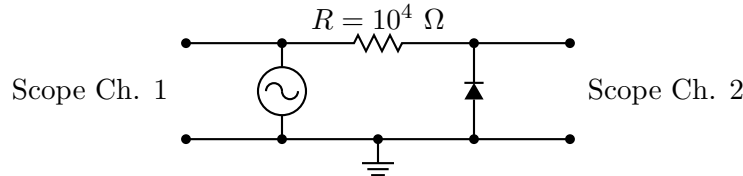

Figure 5.8.

- Measure the DC potential drop across the 10 kΩ resistor with a digital multimeter set to measure DC volts. Compare your result with the prediction

$$V_R = \frac{A}{\pi} \text{ volts} \tag{5.1}$$

A is the amplitude of the potential difference from the function generator, and V_R is the voltage drop across R averaged over one cycle. (When a “DC meter” is connected to a fairly rapidly varying time-dependent voltage, it will display the time-average value of that voltage.) The predicted result is that which would be expected if the diode were ideal.

Derive the result $V_R = A/\pi$.

5.2.2 Current in a Half-Wave Rectifier

- Reconnect the circuit so that CH2 shows you the potential difference across the resistor (Fig. 5.9). Since this potential difference is proportional to the current flow through the resistor and, since the diode and the resistor are in series, we get a signal proportional to the current through the diode. Record and explain what you are seeing.

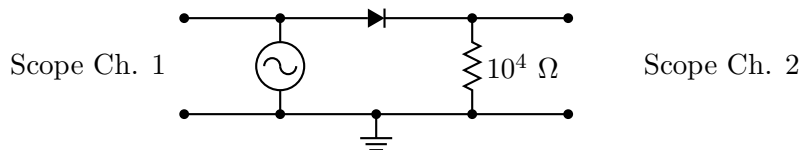

Figure 5.9.

- Reverse the diode. Again, record the new waveform and explain what you are seeing.

- Compare these results with those you found in Part 5.2.1 where you observed the potential difference across the diode.

5.2.3 A Simple DC Power Supply.

Now place a capacitor in parallel with the resistor (Fig. 5.10). (Use the capacitance substitution box.)

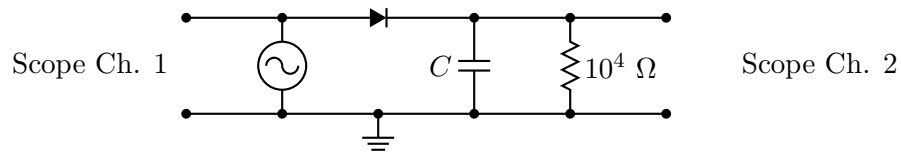

Figure 5.10.

First, vary the capacitance from large values down to small values and notice qualitatively what is happening. Then choose three capacitance values to display the extreme and intermediate effects. For these three values, record the observed waveforms and explain what is happening.

Reverse the diode in the circuit and explain what happens.

5.2.4 Full Wave Rectifier

Using a transformer and four diodes, build a full-wave rectifier. (Your instructors will help you with the main idea.) What are some advantages of a full-wave rectifier? Use a capacitor to complete the full-wave rectifier power supply circuit.

5.3 Supplement: Introduction to Semiconductor Diodes

Many semiconductor diodes are made from silicon. We will consider here the properties of silicon to show how we can understand, at least qualitatively, the behavior of a diode based on the motion of electrical charges in silicon.

5.3.1 Pure Semiconductors

A silicon nucleus contains 14 protons, giving it a charge of +14 units. A neutral Si atom also has 14 electrons, of which ten are tightly bound to the nucleus. We can therefore think of a Si atom as having a central core (charge = +4), surrounded by four rather loosely attached electrons (valence electrons) — represented by the black dots (Fig. 5.11).

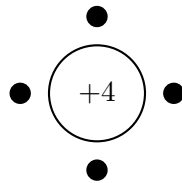

Figure 5.11.

A piece of pure Si is just a collection of these atoms stuck together in a crystal (Fig. 5.12).

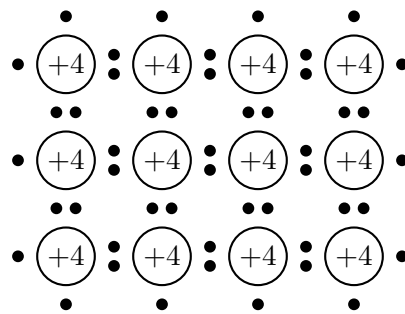

Figure 5.12.

The outer (or “valence”) electrons prefer to be distributed four to each Si. As you can see from the diagram, neighboring atoms share valence electrons as they form chemical bonds, and these bonds hold the solid together.

Pure Si is a pretty good insulator at low temperatures, i.e., near absolute zero. But at slightly higher temperatures Si is not a perfect insulator, since thermal agitation knocks some of the valence electrons loose from their atoms, and application of an electric field can make the electrons flow.

5.3.2 Adding Impurities

The usefulness of semiconductors in modern electronics comes from our ability to control the conductivity of the material by adding controlled amounts of “impurities” (usually at the part per million level) to the pure semiconductor. We distinguish between two types of impurities: donors and acceptors. Phosphorus (P) is an example of a donor impurity; it has an additional unit of charge on the nucleus, and an additional corresponding valence electron. A neutral P atom therefore can be represented as shown in Fig. 5.13.

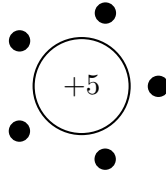

Figure 5.13.

Now we insert a P atom into a piece of Si. The P atom sits in place of one of the Si atoms (Fig. 5.14).

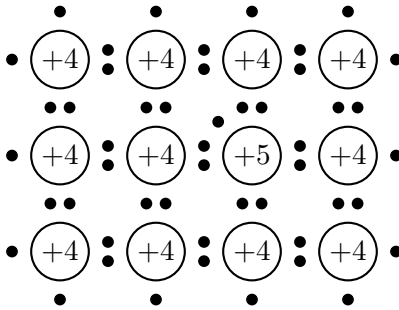

Figure 5.14.

The extra electron does not “fit” into the solid easily. It is quite easily detached from the impurity site. Each impurity atom therefore contributes one electron, which moves about under the influence of any small electric field. This is “n-type” material — lots of extra negative (n) charge carriers, which make this kind of impure Si a decent conductor.

Aluminum (Al) is an acceptor impurity, and is something of the opposite case. A neutral aluminum atom has only three valence electrons (Fig. 5.15).

Imagine inserting such an impurity into a piece of Si in place of one of the Si atoms (Fig. 5.16).

This scheme produces a vacant bonding location, or “hole,” ready and waiting for a passing electron to drop in. If no electric field is applied, the situation should be as pictured. Under

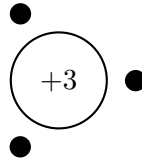

Figure 5.15.

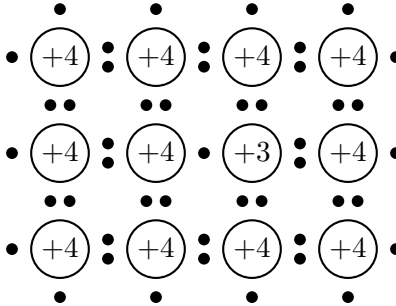

Figure 5.16.

the influence of even a small electric field, one of the electrons from a Si atom may drop into this hole. The electron has left behind a vacant binding location, and we say that “the hole moves to one of the other Si atoms.” The hole can be thought of as mobile (though it is “really” the electrons which move). We can think of the hole something like a bubble in a glass of ginger ale. When we see the bubble move upwards, the surrounding fluid is actually moving downward. This type of impure Si contains mobile holes — it acts as a fairly good conductor, in which current appears to be carried by positive charges — and is called a “p-type” material.

From pure silicon we can make either n-type material (with mobile negative charges) or p-type material (with mobile positive charges), just by “doping” the silicon with donor or acceptor impurities.

5.3.3 PN Junctions

Now let’s imagine that we put a piece of n-type and a piece of p-type silicon in contact with one another. The n-type material has a high concentration of mobile electrons, whereas the p-region has a low concentration of mobile electrons. Hence, some electrons will diffuse from the high concentration n-region to the low concentration p-region, giving the p-region a net negative charge and leaving a net positive charge in the n-region. Similar arguments apply to the mobile holes. Thus, at the boundary between the two materials, the so-called “pn junction,” we have two layers of charge formed, much like that on the plates of a capacitor (Fig. 5.17), where the – and + denote net charges in the two regions. Electrons

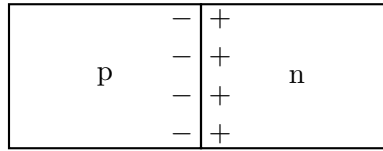

Figure 5.17.

are wandering back and forth across the junction, but in equilibrium the two flows are equal in size.

Consider life as seen by an electron. [For simplicity, let us now ignore the holes; including them will approximately double the effects described below.] An electron in the negatively charged p-region will have a greater potential energy because of the repulsive effect of the negative charge (Fig. 5.18).

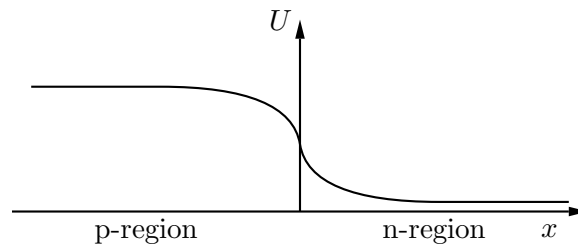

Figure 5.18.

In equilibrium, some electrons on the right go to the left (having enough speed to get up the “hill”); and there is a countering flow of electrons downhill from left to right. The net current is zero, as it must be for equilibrium.

Now let’s connect a battery to the pn junction (Fig. 5.19). This further increases the

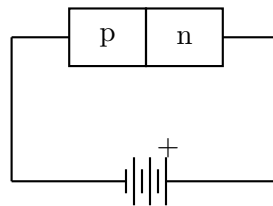

Figure 5.19.

potential energy of an electron in the p-region (Fig. 5.20).

The right-to-left flow of electrons is greatly reduced. There remains, however, a small left-to-right flow. The result is a small net left-to-right flow of electrons, which corresponds to a small conventional current from right-to-left. (Recall that conventional current is identified

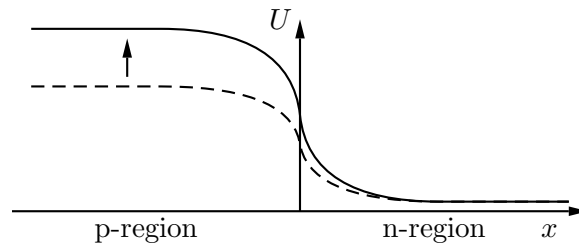

Figure 5.20.

as the current we would see if it were positive charges moving.) Figure 5.21 summarizes the reverse-biased situation.

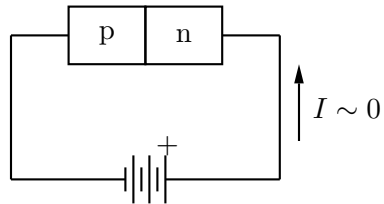

Figure 5.21.

If the battery is connected the other way, however, then we have the electron energy is given by Fig. 5.22.

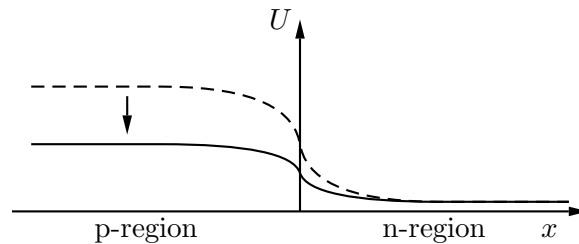

Figure 5.22.

The right-to-left electron flow is greatly enhanced by the lowering of the hill, corresponding to a large conventional current flows from left-to-right. (Mnemonic: to forward-bias a diode, connect the plus side of the battery to the p side of the pn junction.)

We can now identify which side of the circuit symbol for such a diode is p-side and which the n-side (Fig. 5.23), where the arrow denotes the direction in which the conventional current flows more easily.

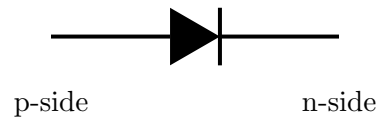

Figure 5.23.

Lab 6

Faraday's Law and Induction

CAUTION: The strong magnets we use can destroy a mechanical (not digital) watch. We suggest removing mechanical watches to begin with and placing them in a safe location. Ignore this suggestion at your own risk.

6.1 Faraday's Law Introduction

It is possible to induce an EMF in a coil of wire by changing the magnetic flux Φ_A passing through the coil that bounds an area A . This laboratory provides a test, both qualitative and quantitative, of some of the ideas inherent in Faraday's law and Lenz's law:

$$\epsilon = -\frac{d\Phi_A}{dt} \quad (6.1)$$

where

$$\Phi_A = \mathbf{B} \cdot \hat{\mathbf{n}}A = BA \cos \theta \quad (6.2)$$

for a uniform magnetic field \mathbf{B} . Here θ is the angle between \mathbf{B} and the normal to the plane of the coil $\hat{\mathbf{n}}$.

Note that Φ_A is equal to BA if \mathbf{B} is parallel to $\hat{\mathbf{n}}$, or $-BA$ if in the opposite direction (we have to denote, arbitrarily, one direction or the other as the direction of $\hat{\mathbf{n}}$), or equal to zero if B is perpendicular to $\hat{\mathbf{n}}$. If the coil has N turns, then the net EMF will be N times the EMF for a single loop of wire:

$$\epsilon = -N \frac{d\Phi_A}{dt}. \quad (6.3)$$

6.2 Determining B field strength from the induced EMF

6.2.1 “One-Shot” Measurements

For *this* part, only a very rough estimate of B need be obtained; if you obtain a result you can trust to within a factor of two, you’re doing OK.

For the experiment you will have available an oscilloscope, a permanent magnet which has a reasonably uniform magnetic field between its pole-faces, a coil of N turns and cross-sectional area A (both given), a motor drive for rotating the coil in the field, and a stopwatch. Use one of the coils for which data are given (see Table 6.1), and record its identification number. Also record the identification number (the “ACPL” number) of the *magnet* you use.

Connect the coil directly to channel 1 of the oscilloscope. Use the DC input setting for the channel. You will want to experiment with the sensitivity and sweep speed settings. Carefully insert the coil between the poles of the magnet and orient the coil so that the plane of the loop is perpendicular to the magnetic field. Quickly withdraw the coil from the region between the pole faces. Observe the sign of the induced EMF and its approximate magnitude. Do this a few times and write down your observations. Estimate how long it took you to withdraw the coil, and with this time estimate, your rough measurement of the size of the EMF, and the given values of N and A , make a rough estimate for B , the magnitude of the magnetic field. (Remember that SI units must be used; your result for B will come out correctly in teslas only if voltages are in volts, areas in square meters, and times in seconds.)

Now vary the orientation of the coil in its initial position between the pole faces, and again withdraw the coil. Observe qualitatively how the size of the EMF varies with the angle of orientation, and with the speed of withdrawal of the coil. Also notice what happens when you move the coil into the region between the pole faces. Write down all of your observations in your lab notebook. While you may include a description of this part in your written report, it is not required.

6.2.2 A Rotating Coil — A Simple Electrical Generator and a Measurement of Magnetic Field Strength

If the coil is rotated with an “angular frequency” ω (radians/second), while located in a steady magnetic field, the flux will vary sinusoidally with time:

$$\Phi_A = BA \sin \omega t. \quad (6.4)$$

(For simplicity’s sake, we will call $t = 0$ the time when Φ_A happens to be zero because the plane of the coil is at that time parallel to B .) Then the induced EMF is, by Eq. 6.3, the

time derivative of this magnetic flux:

$$\epsilon = -NBA\omega \cos \omega t. \quad (6.5)$$

That is, the induced EMF is predicted to vary sinusoidally with angular frequency ω , and with an amplitude (“center to peak”) of

$$\epsilon_{\max} = NBA\omega. \quad (6.6)$$

Detailed Procedures:

1. Mount the coil on the rotator. Make sure the coil will be able to rotate freely in the magnet gap.
2. Measure the frequency of rotation using a stopwatch and the mechanical counter on the rotator. [N.B. Don't forget that there is a difference between angular frequency (radians per second) and (ordinary) frequency (cycles per second). That is, 2π is not equal to 1.]
3. Measure the amplitude ϵ_{\max} of the induced EMF by making connections to the rotating coil with the accessory pieces with two metallic brushes. (ASK one of the instructors if you need help with this.) ϵ_{\max} is obtained from appropriate readings of the oscilloscope trace when the trace is vertically centered on the screen.
4. Use at least 5 different rotation frequencies (ranging from very slow to very fast) and record ϵ_{\max} (from the oscilloscope trace) as a function of rotation frequency.
5. Until now, you have been measuring the frequency with a stopwatch and the mechanical counter. For *one* frequency of rotation, check your measurement of frequency by making appropriate time measurements with the oscilloscope.
6. Make a graph of ϵ_{\max} versus rotation frequency. From these data, and the N and A values for your coil (given in Table 6.1), obtain a value for B . Don't forget to consider uncertainties throughout!
7. As a means of comparison, use the commercial “Hall effect” gaussmeter to measure B for your magnet, and compare it to your EMF determination of B . You may assume that the uncertainty in the gaussmeter is ± 2 in the last digit of the reading.

For your report:

Your report for this part of the lab should focus on the data (ϵ_{\max} versus rotation frequency) and its analysis to find B and its associated uncertainty. You are expected to have a qualitative understanding of how the slip ring apparatus works and why it allows you to get a sinusoidally varying induced EMF.

6.3 Minilabs on Induction

We will have only one setup of each of the following demonstrations. You may do them at any time during the lab period. In fact, it will be helpful and more efficient if you do at least one or two of them early in the lab session.

- Magnet dropped through a series of coils.
- Objects dropped through an aluminum tube.
- A magnetically-damped pendulum.

6.3.1 Falling Magnet

In this demonstration you drop a magnet through a glass tube that has six coils of wire wound around it. The coils are spaced approximately 20 cm apart.

Procedure: The apparatus here is tricky since the scope has to be programmed to make a “single-sweep” record of the trace. Please consult the Instructor before doing this minilab.

As the magnet passes each coil, it induces an EMF in that coil. (Why?)

The coils are connected to the digital oscilloscope, which “records” the signal as a function of time and then displays that signal on the oscilloscope screen. Download the oscilloscope data for your report.

Each of the observed “wiggles” indicates that the magnet has passed through one of the coils. Note that the size and separation of the wiggles changes with time.

Repeat the experiment with the magnet reversed. Again, download the oscilloscope data and present it as a graph.

For your report, explain as many of the features you observe in the oscilloscope traces as you can. Here are some features to get you started: the number of peaks, the height of the peaks, the spacing of the peaks, and the “phase” of the peaks.

6.3.2 Objects Dropped through an Aluminum Tube

There are two “identical” blue cylindrical objects in the box near the apparatus. Drop them one at a time through the long aluminum tube. Write down your observations in your lab notebook along with the answers to the following two questions:

Can you explain why the two objects behave differently?

Why does the spring scale, which supports the metal tube, read differently in the two cases?

You may, but need not, include this part in your written report.

6.3.3 Magnetically Damped Pendulum

1. Move the big magnet far away from the pendulum, then start the pendulum swinging with a small angular displacement (about $10\text{--}20^\circ$). Observe that the pendulum swings many times before coming to a halt.
2. Stop the pendulum. Place the magnet so the pendulum can pass easily between the pole faces.
3. Now release the pendulum from roughly the same starting displacement as you did in part 6.3.3.2. Write down your observations in your lab notebook. Can you explain what happens?
4. Hold the magnet with two hands and pull it quickly away from the pendulum. Again, write down and explain what happens in your lab notebook.

You may, but need not, include this part in your written report.

| Coil # | N | A (cm ²) | Coil # | N | A (cm ²) |
|--------|-----|----------------------|--------|-----|----------------------|
| 1 | 50 | 1.51 | 10 | 100 | 3.15 |
| 2 | 50 | 1.51 | 11 | 200 | 3.40 |
| 3 | 100 | 1.60 | 12 | 200 | 3.40 |
| 4 | 100 | 1.60 | 13 | 50 | 5.96 |
| 5 | 200 | 1.78 | 14 | 50 | 5.96 |
| 6 | 200 | 1.78 | 15 | 100 | 6.12 |
| 7 | 50 | 3.02 | 16 | 100 | 6.12 |
| 8 | 50 | 3.02 | 17 | 200 | 6.47 |
| 9 | 100 | 3.15 | 18 | 200 | 6.47 |

Table 6.1. Coil data.

Lab 7

Inductors

We have seen that when a constant current flows through a wire there is a potential difference across the wire proportional to the current. That is, $\Delta V = IR$. For a capacitor, we know that the charge Q on the capacitor is related to the potential difference by $Q = CV$, where C is the capacitance of the capacitor and depends on its geometry. Another way of writing this relation is in terms of the current,

$$V = \frac{1}{C} \int I dt \quad (7.1)$$

where we implicitly used $I = dQ/dt$.

There is one more device that finds common use in electronic circuits: the inductor. The voltage across the inductor is given by

$$V = -L \frac{dI}{dt}. \quad (7.2)$$

This is the Faraday-Lenz law, where the constant L is the self-inductance of the inductor. The SI unit for self-inductance is the henry

$$1 \text{ henry} = 1 \text{ H} \quad (7.3)$$

$$= 1 \text{ V} \cdot \text{s/A} \quad (7.4)$$

As with capacitance, the inductance is related to constants of nature and the geometry of the coil.

The meaning of the minus sign in the Faraday-Lenz law is that the sense of the voltage produced by the inductor, in response to a changing current, is in such a direction as to oppose the change in the current. Inductors like there to be no changes in the current, and respond by producing a voltage to oppose any changes when they occur.

The symbol for an inductor is shown in Fig. 7.1. As with the capacitor, the symbol represents how one could make an inductor — by winding a helical coil. (In fact, that is how almost all inductors are manufactured.) When current flows through the coil a magnetic field is produced within it, much as an electric field is produced within a capacitor when it is charged. Inductors can store energy, like capacitors do, although they store it in a magnetic field rather than in an electric field.



Figure 7.1.

In this lab you explore some of the behavior of a series circuit containing an inductor and a resistor.

7.1 R - L Circuits (Theory)

Consider the following circuit:

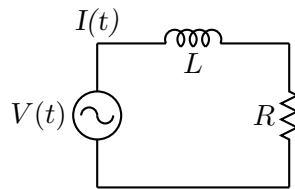

Figure 7.2.

where $V(t)$ is a time-dependent applied EMF, supplied by an oscillator. (In today’s lab, we will use the “square-wave” output of an Agilent function generator, rather than the breadboard function generator). In this circuit, Kirchhoff’s loop rule gives:

$$V(t) - L \frac{dI}{dt} - IR = 0. \quad (7.5)$$

In our application, $V(t)$ is a square-wave, switching back and forth from $V = 0$ to its maximum value, say V_0 :

We are interested in the solution of Eq. 7.5 when $V(t)$ is a constant, either 0 or V_0 . During a time interval such as that denoted by (a) above, we have $V = 0$. Just at the beginning of that time interval, $V(t)$ had been equal to V_0 for a “long” time, so the current had the steady value $I = V_0/R$. So the problem is to solve the equation,

$$L \frac{dI}{dt} + IR = 0 \quad (7.6)$$

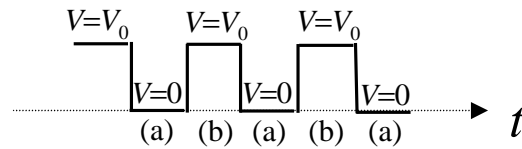

Figure 7.3.

subject to the initial condition that $I = V_0/R$ at $t = 0$.

Similarly, during a time interval such as that denoted by (b) in the sketch, $V(t) = V_0$, and just at the beginning of that time interval, I was 0. So the problem is to solve the equation

$$L \frac{dI}{dt} + IR = V_0 \quad (7.7)$$

subject to the initial condition that $I = 0$ at $t = 0$.

Precisely the same differential equations govern the charging and discharging of a capacitor! In our earlier lab on capacitors, we saw that in those processes the voltage across a capacitor exponentially approaches its final value with a “time-constant” given by $\tau = RC$. (In an exponential of the form $e^{-t/\tau}$, τ is called the time-constant.)

Exercise. Show from Eq. 7.6 that during a time interval such as (a), $I(t)$ decays exponentially with a time constant given by $\tau = L/R$. Likewise, show from Eq. 4.6 that during a time interval such as (b), $I(t)$ exponentially approaches a steady non-zero value, with the same time constant.

Include the above derivation as part of your lab report. Show also that with the henry being an abbreviation for volts-seconds/amperes, the combination henries/ohms indeed has units of seconds!

7.2 The Experiment

1. We will be using the square-wave output of the function generator. Begin by setting the amplitude of the function generator to its largest value. You will need to know the output impedance of the square-wave function generator on this range; it is nominally 50Ω , but you should measure it directly using the method in the capacitor lab.
2. **Write down** the ACPL number for your coil.
3. The coil (inductor) also has some ordinary resistance, which you need to know; measure it with your digital ohmmeter.

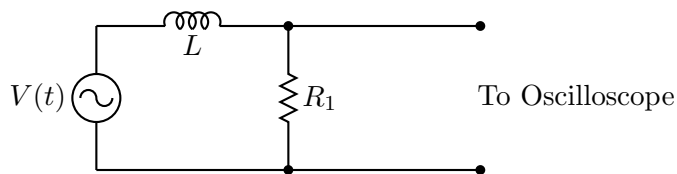

Figure 7.4.

4. Now set up the following circuit (Fig. 7.4), using a nominal $100\ \Omega$ resistor as R_1 :
Be sure that the “SEC/DIV” knob is in the “CAL” position. (Otherwise all your data will be worthless.) The exact frequency of the square-wave oscillator is not important, but it should be low enough so that each exponential growth or decay is essentially complete before being interrupted by the next abrupt change of the square-wave.
Here the oscilloscope measures the voltage across R_1 , which is proportional to the current; thus from what you see on the scope, you can measure the desired time constant. Measure the voltage on the scope as a function of t for one of the “decay” portions of the display.
5. There are a few digital oscilloscopes available for use in today’s lab. When one is free, use it to measure the waveform for exponential *growths* when $R_1 = 100\ \Omega$ and $R_1 = 1\ \text{k}\Omega$. Download your data.

7.3 Analysis: From τ (time constant) to L (inductance).

You will have data for three τ measurements: one from the decay curve you took by hand from the analog oscilloscope, and two for growth curves that you measured for different resistances with the digital oscilloscope. At this point you will want to find the three values of L (with their uncertainties) from the time constants you measure. Remember that the “ R ” in the theoretical expression for τ includes not only R_1 but also the output impedance of the function generator r as well as the resistance of the coil itself (R_L). A more complete circuit diagram taking these impedances into account is shown in Fig. 7.5.

Be sure to combine your uncertainties appropriately to come up with a final value for L . You can use unweighted fits for the data that comes from the digital oscilloscopes; this means that χ^2 does not have any particular meaning. You should still quote your χ^2 from the analog oscilloscope data. Keep in mind that in the capacitor lab almost everyone *overestimated* the uncertainty: see if you can keep from doing that this time.

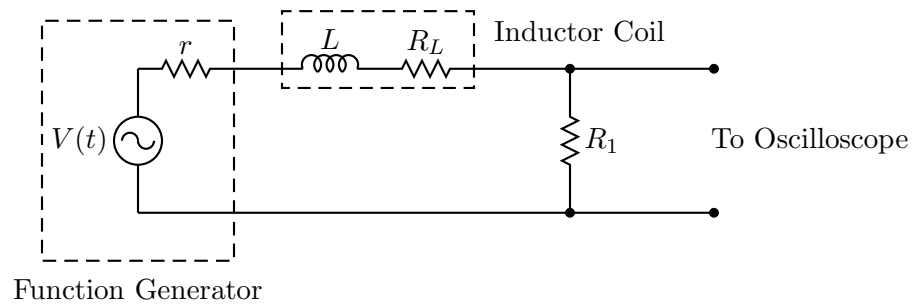

Figure 7.5.

Lab 8

RLC Circuits

In this lab we will put together the three “linear” passive devices with which we have worked in the past few weeks: the resistor, the capacitor, and the inductor. Remarkably, whenever capacitors and inductors appear together in a circuit, Kirchhoff’s voltage rule yields the equation for a simple harmonic oscillator! One important consequence is that the circuit will display the phenomenon of *resonance*.

8.1 Introduction

8.1.1 Capacitors

Recall that the voltage across a capacitor is proportional to the charge on one of the plates:

$$v(t) = \frac{1}{C}q(t) \tag{8.1}$$

We’ll use lower-case letters to represent quantities that change as a function of time. If we indicate the current $i(t)$ that flows as the capacitor is discharging, we have the following situation (Fig. 8.1):

Since the current results in the charge $q(t)$ changing with time, we have, with the signs used in the figure,

$$i(t) = -\frac{dq(t)}{dt} \tag{8.2}$$

$$= -C\frac{dv(t)}{dt} \tag{8.3}$$

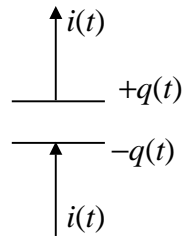

Figure 8.1.

8.1.2 Inductors

Now consider the potential difference for an inductor. From Lab 7, we know that

$$v(t) = -L \frac{di(t)}{dt}. \quad (8.4)$$

Eqs. 8.3 and 8.4 suggest that capacitances and inductances are in some sense “complements” of one another:

- For a capacitor, the current is proportional to the time derivative of the voltage.
- For an inductor, the voltage is proportional to the time derivative of the current.

This situation might remind you of the relationship between velocity and position for the motion of a mass on a spring or the motion of a simple pendulum. In some sense, it is the interplay of position and velocity that leads to the interesting behavior of springs and pendulums.

8.1.3 LC Oscillations — a simple case

The following circuit is the simplest imaginable one containing both an inductor and a capacitor (Fig. 8.2):

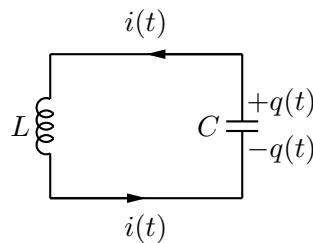

Figure 8.2.

Suppose that at $t = 0$, the capacitor is (somehow) charged as shown. As in an “ RC ” circuit, current will start to flow, but (unlike the case of the RC circuit) $q(t)$ will not simply decay monotonically to zero; it will overshoot. The capacitor will become oppositely charged, then current will flow clockwise, and so on. The system continues to oscillate spontaneously, much like the (undamped) oscillations of a mass on a spring.

Here is the mathematical argument: Use Kirchoff’s Voltage (Loop) Rule, and add the voltages around the loop, equating the sum to 0:

$$L \frac{di(t)}{dt} - \frac{q(t)}{C} = 0 \quad (8.5)$$

[The sign is correct, though the proof of that claim is omitted; the sign conventions for $i(t)$ and $q(t)$ are those adopted in Fig. 8.2.]

We want to focus our attention on the charge $q(t)$; so, we note that for the discharge of the capacitor

$$i(t) = -\frac{dq(t)}{dt} \quad (8.6)$$

and taking a derivative yields

$$\frac{di(t)}{dt} = -\frac{d^2q(t)}{dt^2} \quad (8.7)$$

Using Eq. 8.7 in Eq. 8.5 gives us

$$L \frac{d^2q(t)}{dt^2} = -\frac{1}{C}q(t) \quad (8.8)$$

But this is an old friend, the simple harmonic oscillator equation describing a mass on a spring, whose equation of motion is

$$m \frac{d^2x(t)}{dt^2} = -kx(t) \quad (8.9)$$

Comparing Eqs. 8.8 and 8.9, you might well choose to describe L as an inertia (“mass”) term for a circuit. Just as a mass on a spring overshoots the equilibrium position (because of its inertia, because of Newton’s First Law), the charge through a coil “tends to keep going” — Faraday’s law inhibits sudden current changes just as Newton’s First Law inhibits sudden velocity changes. Similarly, the reciprocal of the capacitance plays the role of a spring constant. Since you know the solution to Eq. 8.9 (simple harmonic oscillation with angular frequency $\omega = \sqrt{k/m}$, sometimes called, for reasons that will become clear in this lab, the resonant frequency), you can immediately predict the solution to Eq. 8.8! Those solutions are oscillatory in time with frequency $\omega = 1/\sqrt{LC}$.

8.1.4 LCR circuit with a sinusoidal EMF

What has been omitted from the preceding, nearly rigorous, theory is the role of the resistance that is inevitably present. Whereas capacitors store energy (in electric fields) and inductors store energy (in the magnetic fields), resistors dissipate energy, producing heat. If a small amount of resistance is present, we will observe a “damped” sinusoidal oscillation (a sinusoid of steadily diminishing amplitude). If a large amount of resistance is present, the overshoot characteristic of oscillation may not even be seen. Let us therefore add some resistance to the circuit shown in Figure 8.2 and to compensate for the loss of energy we will add a sinusoidal EMF, of adjustable frequency.

Now our circuit would look like this (Fig. 8.3):

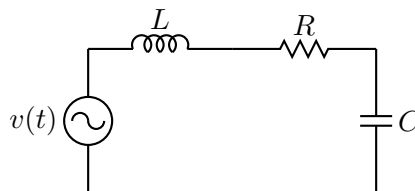

Figure 8.3.

The EMF can “drive” an oscillatory current in this circuit (alternately clockwise and counterclockwise), maintaining the amplitude of such a current at a steady value in spite of the energy being dissipated in the resistance. The frequency of this current will be the same as the frequency of the oscillatory EMF, but one might well expect (correctly) that the size of the resulting current will be greatest when the frequency of the driving EMF matches the natural resonant frequency of the LC circuit, the frequency of natural oscillations that you would predict from Eq. 8.8.

You might try the analogous experiment with a pendulum constructed from an object tied to a string. Hold one end of the string in your hand and shake it at various frequencies.

Here is another way of coming to the same conclusion. If we consider Eq. 8.3 and assume that the potential across the capacitor is given by

$$v(t) = V \sin \omega t \quad (8.10)$$

then we see that

$$i(t) = \omega CV \cos \omega t \quad (8.11)$$

Equation 8.11 tells us two things. First, the amplitude of the current is related to the amplitude of the oscillating EMF $I = \omega CV$. If we recall Ohm’s Law, we see that for a capacitor $1/(\omega C)$ plays the role of resistance. (In the jargon of electronics, $1/(\omega C)$ is called the impedance of the capacitor.) The crucial point is that the impedance of the capacitor varies with frequency. For high frequencies, for which the current is rapidly oscillating

in time, the capacitor does not have a chance to charge or discharge very much, and its effect (impedance) in the circuit is small. For very low frequencies, the capacitor has a very high impedance and prevents very slowly changing currents from flowing in the circuit. Secondly, there is a phase difference of 90° between the current and the potential difference for a capacitor.

Exercise 1.

- Show that $1/(\omega C)$ has units of ohms.
 - Sketch a graph of $v(t)$ and $i(t)$ from Eqs. 8.10 and 8.11.
-

Now let's look at an inductor using Eq. 8.4. Suppose that the current varies sinusoidally with time

$$i(t) = I \sin \omega t \quad (8.12)$$

Then Eq. 8.4 tells us that

$$v(t) = \omega L I \cos \omega t \quad (8.13)$$

Again we see that there is a 90° phase difference between the current and the potential across the inductor. We also see that the product ωL gives us the impedance of the inductor. This impedance is high at high frequencies, because the inductor strongly opposes the rapidly changing current. For low frequencies, the inductor has almost no effect.

Look again at Fig. 8.3. A capacitor acts “like” a resistance of size $1/(\omega C)$, and an inductor “like” a resistance of size ωL , and there is a 180° phase difference between the potential across the inductor and the potential across the capacitor. At some intermediate frequency where those two “resistances” are of equal size, where the “blocking” effects of the L and C “annihilate” each other, then the maximum (amplitude of) current can flow.

This frequency-dependent response is called RESONANCE. The frequency where the cancellation occurs is called the resonant frequency (denoted f_0), and the corresponding angular frequency is denoted by ω_0 . From our arguments, we predict that the resonant frequency satisfies the following condition:

$$\omega_0 L = \frac{1}{\omega_0 C} \quad (8.14)$$

CAUTION: $\omega_0 \neq f_0$ because $2\pi \neq 1$.

Exercise 2. Suppose $L = 10$ mH (10^{-2} H) and $C = 0.001$ μ F. Find the numerical value of the resonant frequency f_0 .

8.2 The Experiment: LCR Series Resonance

We will want to use the oscilloscope to examine the potential difference across the inductor and the capacitor as well as across the resistor. In order to carry out these measurements, we need to set up the oscilloscope in its so-called differential mode, in which the display is proportional to the potential difference between the connection to the CH1 input and the connection to the CH2 input. (We need to use this mode because we can only have one “ground” point in a series circuit.)

First, connect a wire of one color to the CH1 input (red terminal) and a wire of a different color to the CH2 input (red terminal).

Use the following oscilloscope settings:

- VERTICAL controls
 - CH1 BOTH CH2 — set to BOTH
 - CH2 INVERT
 - ADD ALT CHOP — set to ADD
 - CH1 DC CH2 DC
 - 1 VOLT/DIV for both channels

Please note: In this differential mode, in which the display vertical deflection is proportional to CH1-CH2, it is **essential** that both CH1 VOLTS/DIV and CH2 VOLTS/DIV be at the **same** setting.

- HORIZONTAL controls
 - MODE $\times 1$
 - SEC/DIV - 20 $\mu\text{s}/\text{div}$
- TRIGGER controls
 - P-P AUTO
 - SOURCE: Both buttons to the EXT position

Connect the SYNC output on the function generator to EXT INPUT on the trigger section of the oscilloscope, using a coaxial cable. With a BNC “tee” and another coaxial cable, connect the sync output to the frequency counter as well.

- FUNCTION GENERATOR Settings:
 - SINE WAVE output
 - VOLTS OUT - depressed for 0-2 V setting

- all other push buttons in the OUT position
- AMPLITUDE - fully clockwise

Using the capacitance substitution box for C , set up the following circuit (this is really just like Fig. 8.3):

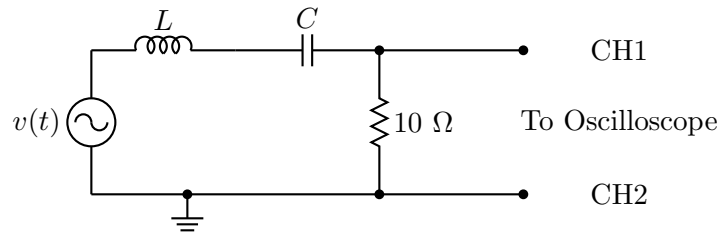

Figure 8.4.

For L , use the inductor you used in Lab 7. For C , use a “capacitance substitution box,” set initially at $0.001 \mu\text{F}$. Using the value of L you found earlier, make a rough estimate of the expected resonant frequency. (You should have done this in Exercise 2).

Set the Function Generator to produce a sinusoidal EMF and look for the resonant frequency. Vary the Function Generator’s frequency until you find the resonance. Once you have it, admire the resonant character of the circuit’s response by varying the frequency back and forth through f_0 .

Plot the amplitude of the signal as a function of the frequency, as measured with the digital frequency counter. You should take about eight points, keeping in mind that the central value of the resonance is determined by the steep parts of the curve, not the flat part near the top of the curve.

Repeat this measurement for about five other C values in the range $0.001 \mu\text{F}$ to $0.22 \mu\text{F}$.

Measure the C values in the substitution box using a digital capacitance meter. [It is more accurate than the nominal values printed on the substitution box; the principles on which this capacitance meter operates are the same as those used in the “Capacitors” lab.]

From Eq. 8.14, it follows that a graph of C vs $1/f^2$ should be a straight line, from whose slope you can find L . Make such a graph, find L , and compare it with the value you found for L in a previous lab.

8.3 Two Puzzles

8.3.1 Initial Measurements

Pick one of the eight capacitance values you used in Sec. 8.2 that has a capacitance $< 0.015 \mu\text{F}$. With the CH1 and CH2 wires connected to opposite ends of the 10Ω resistor, set the function generator frequency so that it is at the resonant frequency for this capacitor. Then move the CH1 and CH2 wires to determine successively the amplitude of:

- the emf from the function generator;
- the potential drop across the capacitor;
- the potential drop across the inductor;
- and the potential drop across the resistor.

In your lab report, explain these “puzzling” features of your results:

1. Kirchhoff’s Voltage Rule appears to be violated: the emf amplitude (from the function generator) is not equal to the sum of the amplitudes of the potential drops around the circuit.
2. The amplitude of the potential difference across the capacitor (or the inductor) is larger than the amplitude of the emf from the function generator: we are getting out “more voltage” than we are putting in.

Hint: pay attention to the phase of the waveforms that you observe on the oscilloscope screen. These can be compared since you are triggering the oscilloscope on the SYNC OUT signal from the function generator, which is the same for all the signals, rather than on the observed waveform itself. If this is cryptic you can ask an instructor for assistance.

A phasor diagram or two may also come in handy.

Lab 9

Properties of Light

9.1 Snell's Law

In this part of the lab, you will investigate the fundamental relationship between incident and refracted light beams. This is the foundation for building more complicated refractive optics such as lenses and optical instruments consisting of combinations of lenses. Snell's Law states that for light incident at a normal angle θ_1 on a smooth interface between two materials of indices of refraction n_1 and n_2 , the normal angle θ_2 of the refracted light is related to θ_1 by

$$n_1 \sin \theta_1 = n_2 \sin \theta_2. \quad (9.1)$$

9.1.1 Materials

laser, polar ruled paper, D-shaped gelatin in a thin plastic mold

9.1.2 Procedure

1. Place the D-shaped semicircle of gelatin ("stiff water") within its plastic holder on top of the polar ruled acetate sheet. Place the gelatin in such a way that the straight side is aligned with the 90-270 degree line on the paper, and so that the midpoint of the straight side sits at the center of the polar grid, as shown in Fig. 9.1. Set the laser so that the light beam shines through the circular "wall" of the gelatin and exits at the midpoint of the straight side (see Fig. 9.1, below). The light will enter the gelatin normal to its surface. You will need to set the height of the laser (by propping it up on a book or some such object) so that you can see the entrance and exit of the laser light.

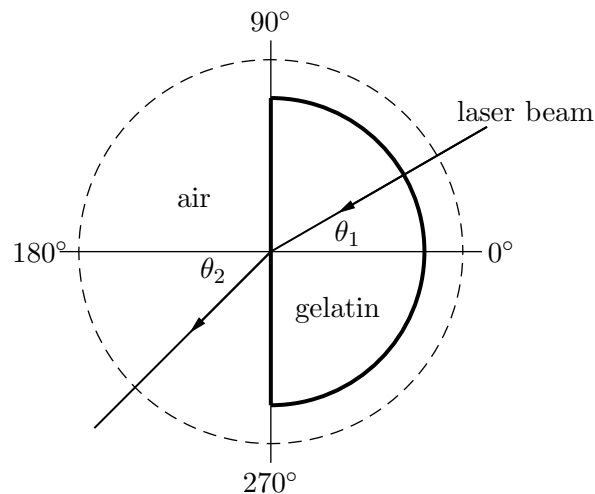

Figure 9.1.

2. Rotate the laser beam until you discover the angle θ_C for total internal reflection for water. (Make sure that the beam is exiting at the midpoint of the straight side.) What is it? Use it to determine the index of refraction of water from the relation $\sin \theta_C = 1/n_W$.
3. Record the incident and refracted beam angles, θ_1 and θ_2 , respectively, starting with $\theta_1 = 0$ and increasing θ_1 in 5° increments for as many data points as you can. Make sure to read the θ_2 values relative to the normal, i.e., relative to the 180° line.

9.2 Light Intensity Minilabs

In this section of the lab, you will investigate some of the fundamental properties of visible light. There are two (or so) setups for each minilab, so you will need to circulate from station to station.

9.2.1 Inverse Square Law Behavior

Here you will explore the phenomenon that light from a point source propagates outward uniformly in all directions about the source. Without any optical interference, such as lenses, mirrors, or interfaces, light will propagate outward from a point source in a straight line, filling a spherically symmetric volume. Because the total energy per unit time produced by the source is constant, the intensity (energy per unit area per unit time) must fall off with distance from the source. In fact, since the area of a spherical shell surrounding the source increases as the square of the distance r from the source, the intensity I is expected

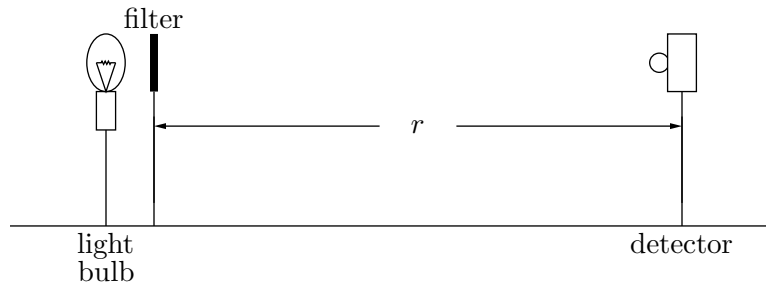

Figure 9.2.

to exhibit “inverse square law behavior” when measured as a function of r .

Exercise I

Write down a mathematical expression that relates I to r as described in words in the previous sentence. Draw a picture if this helps.

Experiment And Analysis I

On an optical bench, align a light bulb 10 cm in front of a photo sensor (light detector), as shown in Fig. 9.2. The detector is designed so that it will give an output voltage proportional to the intensity of the light hitting the sensor so long as the voltage is less than 300 mV. That is, for low intensities, the detector responds linearly to the intensity. We will want to conduct this experiment in the linear region of the detector. To make sure this happens, place a holder that contains a collection of light absorbers (these are actually just partially darkened overhead transparencies cut into 2 inch squares) between the bulb and the detector so that the output reading is close to but not more than 300 mV. The absorber (filter) allows only a fraction of the light to penetrate through it. It should be positioned very close to the bulb.

Examine qualitatively what happens to the intensity when the source-detector spacing r is gradually increased. Take quantitative measurements of the detector output voltage V vs. r for at least 10 readings between 10 cm and 80 cm. Take more data points closer to the course since that’s where the change in V is the greatest. You will have to subtract off any nonzero background (i.e., your bulb off) voltage from the V readings, so make sure to record the background in your notebook, too. First, make a plot of V (corrected) vs. r . Then employ the commonly-used method of straight-line graphing to plot your data in such a way that you observe a straight line. A log-log plot will help with this. (Why?) How linear are your results? What is the slope, and how does it compare to the expected value of slope from the expression you determined in Exercise 1? Can you identify reasons for any discrepancies by looking carefully at your plot?

9.2.2 Malus's Law for Polarization

Certain materials (such as the polymers in our polarizers) have the ability to respond to an incident electric field by absorbing all of the light that has an electric field aligned with the polymers, and re-radiating the light that does not. We can think of light incident on a polarizer as having two components of electric field, one aligned with the polymers, and one perpendicular to that direction. (The third dimension, perpendicular to the plane of the polarizer, is unaffected and need not be considered here.) The light that makes it through the polarizer is the perpendicular component. We say that the transmitted light is *polarized* because it comes out having an E -field in a single, well-defined direction (that we might mark on the polarizer with an arrow), regardless of what its E -field orientation was to begin with. This is good news for those of us who wear sunglasses since the polarizer acts somewhat as an E -field filter and cuts the transmitted light intensity way down.

To get polarized light in the first place, we can pass unpolarized light (light with many random orientations of the E -field vector, such as the light from our bulb) through one polarizer. It turns out that in that case, half of the incident light intensity makes it through. If you shine that polarized light onto a second polarizer, the polarization of the output light is determined by the second polarizer, as discussed above. But the intensity of that light depends on the relative polarization angles of the polarizers. Malus's Law describes the overall output intensity as a function of the angle θ between the alignment axes of the two polarizers. In fact, Malus's law says that the output intensity (out of the second polarizer) and the input intensity (out of the first polarizer) are related by the factor $\cos^2 \theta$.

Exercise II

Write down the mathematical expression that is described in the previous sentence.

Experiment and Analysis II

First, get a qualitative feel for the effect of crossed polarizers by looking through a stack of two polarizers and rotating one relative to the other. You'll probably need to do this in a well-lit room. What do you notice about the light intensity? Do your observations make sense in light of the above discussion?

Set up on the optical bench the laser, a polarizer holder, a rotatable polarizer, and the detector, as shown in Fig. 9.3. The first polarizer should be aligned so as to pass the inherently polarized laser light beam. Direct this light through the second polarizer and adjust its orientation so the transmitted intensity is a maximum. The transmission axes of the two polarizers are now parallel to one another. Adjust the distance between the second polarizer and the detector so that the measured intensity does not exceed 300 mV on the

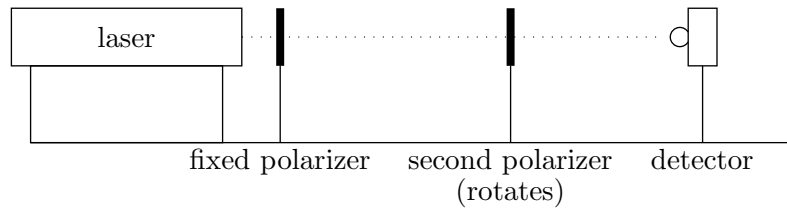
**Figure 9.3.**

multimeter for this maximum transmitted intensity. Record the measured intensity V every 10° by varying the angle between $\pm 90^\circ$. Because these polarizers are only partially effective, you may notice a baseline offset. For your data, subtract off this baseline and try a plot of V vs. $\cos^2 \theta$. (Beware of software that assumes you've entered the data in radians.) What do you find? Is it consistent with your expectations?

For your report and exit interview: We will ask you to show all calculations and graphs, including your work on the exercises. Please make sure to answer all questions posed in the handout.

Lab 10

Geometric Optics

If a point source is a distance s from a “thin” lens, then light diverging from the source will be refracted by the lens and will converge at a distance s' from the lens (see Fig. 10.1). Here s and s' are related to the focal length, f , of the lens by the Gaussian lens equation:

$$\frac{1}{s} + \frac{1}{s'} = \frac{1}{f}, \quad (10.1)$$

where f is a length characteristic of the particular lens used. Its value depends upon the radii of curvature of the spherical surfaces of the lens and on the material of which the lens is made. (Note: in the drawing we assume $s > f$.)

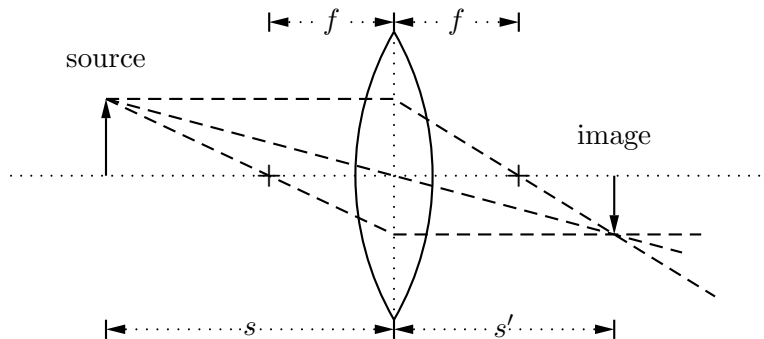

Figure 10.1.

If a screen were placed at s' , then a bright spot would appear on the screen. If, instead of a point source, we had an extended source a distance s from the lens, then a focused image of this extended source would appear on the screen at a position s' . Indeed, if we placed a photographic plate instead of a screen at this position, we would have the makings of a camera.

In today's lab, you will test the validity of equation 10.1.

Part I. If an object is very far from the lens ($s \gg f$), then $1/s \ll 1/f$.

In this case we expect from the equation that the distant object will be focused at a distance $s' = f$. To get a crude idea of the focal length of the lens you are using, find some very distant bright object (e.g., a mountain or a tree) and measure the distance from the lens to a point where the light is focused. Be sure to include with your measurement an estimate of the uncertainty associated with f .

Part II. You have been provided with a light source, a screen, an optical bench, and a meter stick. Using these, set up an experiment to test the validity of Eq. 10.1. Plot your data in such a way that, if the theory is correct, you ought to obtain a straight line graph from which you can obtain the focal length of the lens. Again, be sure to estimate the uncertainty in your measurement. Does your value deduced here agree with that obtained in Part I? While making these measurements, observe the characteristics of the image produced. Is the image larger or smaller than the original object? Is the image inverted?

Part III. Repeat Part II with a different lens with a different curvature, and hence focal length. Which lens has the larger f ? For which lens are the surfaces more curved (i.e., depart further from being planes)? Which lens is “stronger”?

Part IV. Take one of the “negative” lenses. Estimate its focal length by using the method of parallax (or some other method) to ascertain the position of virtual images produced by the lens. We use parallax all of the time to determine which of two objects is closer than the other. You will want to apply the method of parallax to the image of a distant object viewed through the lens and a (closer) object viewed outside of the lens.

Lab 11

Interference and Diffraction

In our last laboratory on geometric optics we treated light as if it were composed of rays. While this approximation is usually adequate for objects which are large compared to the wavelength of light, it is not adequate for describing the interaction of light with small objects. In this case, it is necessary to consider light as an electromagnetic wave. The electric and magnetic fields associated with a light wave are always perpendicular to the light propagation direction. The magnitude of the electric field associated with a beam of light propagating in the x -direction may be written as

$$E = E_0 \cos \left[2\pi \left(\frac{x}{\lambda} - ft \right) \right]. \quad (11.1)$$

This describes a “travelling” wave with an amplitude E_0 and a velocity equal to $f\lambda$, where f is the frequency of the light and λ is the light’s wavelength.

The intensity of an electromagnetic wave is proportional to the total electric field squared (E^2). Because light is a wave, it may exhibit the property of interference. Consider what would happen if two electromagnetic waves were travelling in the same direction but with their phases shifted by 180° . That is, we let one wave have its maximum just as the other is at its minimum. The total electric field is just the sum of the electric fields associated with each beam, in accordance with the principle of superposition.

So

$$E = E_1 + E_2 \quad (11.2)$$

$$= E_0 \cos \left[2\pi \left(\frac{x}{\lambda} - ft \right) \right] - E_0 \cos \left[2\pi \left(\frac{x}{\lambda} - ft \right) \right] \quad (11.3)$$

$$= 0. \quad (11.4)$$

The field associated with the second beam will exactly cancel the first and there is no net field. Since there is no field, there is no intensity, and hence we would see no light. This phenomenon is called total destructive interference. Alternatively, we could imagine two

electromagnetic waves having the same amplitude and phase. Then the total field would simply double:

$$E = E_1 + E_2 = 2E_0 \cos \left[2\pi \left(\frac{x}{\lambda} - ft \right) \right]. \quad (11.5)$$

Because the intensity of light is proportional to the square of the electric field the intensity would quadruple. This phenomenon is called “constructive” interference.

Today we would like to observe these “wavelike” properties of light. To do this we will do Young’s double-slit diffraction experiment. In this experiment an electromagnetic wave is incident upon two narrow apertures. We let the separation between the two apertures be d . The electromagnetic wave will exit the two slits with approximately the same amplitude and phase. If we place a screen some distance D away from our two slits, the electromagnetic waves propagating from the two slits will combine to illuminate the screen (see Fig. 11.1).

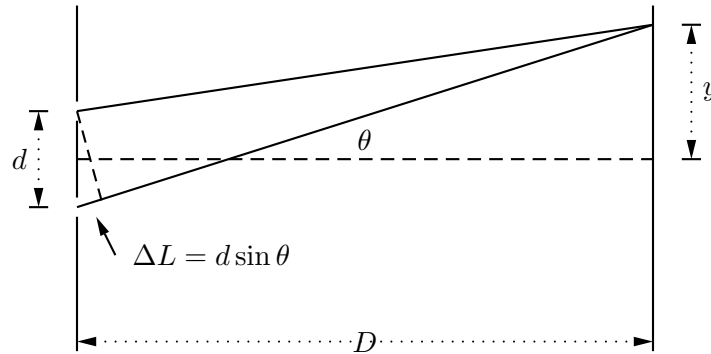

Figure 11.1.

The distance traveled by the wave from slit 2 to the screen is longer than that traveled by the wave from slit 1. The difference in the path lengths is approximately equal to

$$\Delta L = d \sin \theta \quad (11.6)$$

where θ is the angle shown in the figure.

Now, if $y \ll D$, then θ is small and $\sin \theta = y/D$. The difference in travel distances is then $\Delta L = yd/D$.

If this path difference is equal to $n\lambda$, where n is an integer, then there will be a constructive interference and we will see a bright spot on the screen. Thus the positions of the bright spots will be at positions y_n given by

$$n\lambda = \frac{y_n d}{D} \quad \text{or} \quad y_n = \frac{nD\lambda}{d}. \quad (11.7)$$

The separation between two successive bright spots will then be given by

$$\Delta y = y_{n+1} - y_n = \frac{D\lambda}{d}. \quad (11.8)$$

Similarly, for points where the path difference ΔL creates a phase shift of 180° there will be destructive interference and no light will be observed. These points of destructive interference will be halfway between the bright maxima. They will also be separated by a distance

$$\Delta y = \frac{D\lambda}{d}. \quad (11.9)$$

If we measure Δy , d , and D , we can in principle measure the wavelength of the incident light.

In order to perform this experiment a helium-neon (He-Ne) laser will be used. Lasers create light that propagates only in a particular direction and is monochromatic (i.e., it has only one frequency or wavelength). You will determine the wavelength of this laser light from your double slit interference experiment.

Part I. You have been provided with a photographic plate that has a column of double slits. For our lab today we will use at least two of these double slits. For ease of measurement we recommend the second- and third-widest double slit pairs on your film; note that in the “series” of double-slits, the narrowest is actually only a single slit.

For at least these two slit pairs measure the distance d between the slits as follows: put the whole photographic plate on an overhead projector to magnify the image. Measure the slit width of the image as well as the width of the whole photographic plate and its image at the horizontal line through the slits whose width is being measured. Because the slits have a finite width, you may want to measure edge to edge and average your results for left edges and right edges to get a value for d . Repeat this measurement enough times so that you have a good idea of the uncertainty in d .

Part II. Shine your laser beam onto one of the double slits that you have measured. Place a screen at large distance D (at least a couple of meters) away from the double slit. You should observe several points of constructive and destructive interference. To get maximum sensitivity here it is important that the ambient light be dim. Measure the distance between successive minima. To get the best precision in this measurement, measure the interval over several successive minima and divide by the number of intervals. From your measurement, determine the wavelength of the He-Ne laser. Be sure to include an estimate of the uncertainty in your measurement. (CAUTION: You will see successive brightening and dimming of the maxima as you move away from the center. This is an interference effect associated with the finite slit widths. Do not confuse it with the double-slit interference pattern.)

Part III. Repeat Part II for your second slit pair. Obtain a second value for the He-Ne wavelength. In which measurement do you have more confidence? Why?

Part IV. A remarkable prediction of our treatment of light as a wave is that the intensity at the points of destructive interference will be zero when both slits are open, but non-zero when light is arriving from either slit alone. That is — when we open the second slit, we *decrease* the light intensity at these points! See if you can observe this effect by covering and uncovering one of your slits.

Appendix A

Keeping a Lab Notebook

Keeping a good lab notebook seems like a simple and obvious task, but it requires more care and thought than most people realize. It is a skill that requires consistent effort and discipline and is worth the effort to develop. Your lab notebook is your written record of everything you did in the lab. Hence it includes not only your tables of data, but notes on your procedure, and your data analysis as well. With practice, you will become adept at sharing your time fairly between conducting the experiment and recording relevant information in your notebook as you go along.

You want all this information in one place for three main reasons, and these reasons continue to be valid even after you leave the introductory physics laboratory. (That is, even — or rather, especially — practicing scientists keep lab notebooks.) First, your lab notebook contains the information you will need to write a convincing report on your work, whether that report is for a grade in a course or a journal article. Second, you may need to return to your work months or even years after you have finished an experiment. It is surprising how often some early experiment or calculation is important in your later work. Hence you need a reasonably complete account of what you have done. Third, your lab notebook is also the source to which you turn in case someone questions the validity of your results. (You may have followed the famous David Baltimore case of alleged scientific fraud, in which the lab notebook of one of Baltimore's collaborators has been the subject of careful scrutiny.)

Your notebook therefore serves two purposes that may not be completely compatible with each other. On one hand, you should write things down pretty much as they occur and before you have a chance to forget them, so that you have a complete record of your work in the lab. On the other hand, your notebook should be reasonably neat and well-organized, partially so you can find things and partially so that if anyone questions your results, not only will they be able to find things, but the layout of your notebook will suggest that you investigated the problem carefully and systematically.

You should use a bound lab notebook (that is, not a loose leaf notebook). So-called quadrille

notebooks (with rectangular grids on each page) are particularly handy for making graphs and tables. We strongly recommend that you leave every other sheet in your lab notebook free, so that you can jot down additional comments and/or add graphs onto those blank sheets after the fact. If you wish to add a graph done on a computer or a graph done on regular graph paper to the notebook, you may simply tape or glue the graph into your notebook.

Next, we will discuss some of the information that goes into your lab notebook.

Introduction

You should begin each new experiment on a fresh page in your notebook. Leave some room for pre-lab lecture notes. Start with the date and brief title for the experiment — just enough to remind you what that section of your notebook is about. Then give a list of the equipment, identifying large pieces of equipment with manufacturer's name and the model. For large pieces of equipment, record the serial number, too. With this information, you can repeat the experiment with the identical equipment if for some reason you are interrupted and have to return to the experiment much later. Or, if you are suspicious of some piece of equipment, having this information will let you avoid that particular item.

Sketch of the Setup

Also make a quick sketch of the setup, or a schematic diagram (for electronics). Schematics will be especially helpful in the second semester of physics when you will be connecting various pieces of electronic equipment together in mildly complicated ways. Also in optics experiments, ray diagrams are useful to keep track of the paths of various light rays.

Outline of Methods

Next, give a short paragraph noting the main goal of the experiment and outlining how you expect to carry out your measurements. This should not be too detailed, since you will probably modify your procedure as you go along. But this opening paragraph will help you settle in your own mind what you do to get started. Particularly as the semester goes on and you develop more and more of the experimental procedure yourself, you will find yourself modifying your initial procedure, discovering additional variables that should be recorded and revising your approach. So you don't want to get too locked in to one format. But you also should avoid writing down data or procedures in the nearest blank space, or you'll be cursing yourself when you look for that piece of information later. So the cardinal rule of keeping a lab notebook is this: give yourself plenty of space. Doing so makes extending tables or descriptions of procedure easy, and typically also makes your notebook easier to

read. If you find that you haven't allotted enough space for a table, feel free to start it over on the next page — labeling the new table, of course, and making a note at the old table directing you (or someone else) to the new one. Using only the odd-numbered (or even-numbered, if you're left-handed) pages also works well; the blank facing page can be used later to reduce data, where you can see both the raw data and the reduced data, or for graphs. Or you can use all the pages, but start out using only the top half of each page.

Procedure

In recording your procedure, write in complete sentences and complete paragraphs. This is part of the discipline required for keeping a good lab notebook. Single words or phrases rapidly become mysterious, and only with a sentence or two about what you're measuring, such as the period of the pendulum as a function of length, will you be able to understand later on what you did. Give more details where necessary, if for example the lab manual does not give a more detailed procedure or if you depart from the procedure in the manual.

Numerical Data

When recording numerical data, keep your results in an orderly table. You should label the columns, and indicate the units in which quantities are measured. You should also indicate the uncertainty to be associated with each measurement. If the uncertainty is the same for a certain set of data, you can simply indicate that uncertainty at the top of the column of that data.

You will need at least two columns: one for the independent variable and one for each dependent variable. It's also good to have an additional column, usually at the right-hand edge of the page, labeled "Remarks." That way, if you make a measurement and decide that you didn't quite carry out your procedure correctly, you can make a note to that effect in the "Remarks" column. (For example, suppose that you realize in looking at your pendulum data that one of your measurements must have timed only nine swings instead of ten. If you indicate that with, say, "9 swings?" you could justify to a suspicious reader your decision to omit that point from your analysis.)

Do not Erase

It is always a good idea to record data, comments, and calculations in ink rather than in pencil. That way, you avoid the temptation to erase data that you think are incorrect. You never should erase calculations, data, comments, etc., because the original data, calculation, and so on may turn out to be correct after all, and in any case you want to keep a complete record of your work, even the false starts. If you believe that a calculation, for example is

wrong, it is better to draw a line through it and make a note in the margin than to erase the calculation. You can always make things neat in your report.

Sequences of Measurements

You will often be performing experiments in which you have two independent variables. Usually in such experiments you fix the value of one independent variable and make a series of measurements working through several values of the other variable. Then you change the value of the first variable and run through the measurements with the other variable again; then you change the first independent variable again, make another set of measurements, and so on. It's usually easier to set up this sort of sequence in your notebook as a series of two-column tables (or three columns with 'Remarks') rather than a big rectangular grid. "Title" each table with the value of the independent variable that you're holding fixed, and keep the format of all of the tables the same.

Comment on Results

Once you have completed the experiment and performed any necessary calculations in the notebook, you should look back to the main goal and write down to what extent it was achieved. If, for example, you were making a measurement of g , you should include a clear statement of the value of g along with its uncertainty. Be aware that there are often secondary goals as well (to become familiar with a particular physical system or measurement technique, for example). Comment on your success in attaining these goals as well. This serves as a statement of conclusion and gives you the chance to make sure the lab was completed thoroughly and to your satisfaction.

Appendix B

Graphical Presentation of Data

B.1 Introduction

“Draw a picture!” is an important general principle in explaining things. It’s important because most people think visually, processing visual information much more quickly than information in other forms. Graphing your data shows relationships much more clearly and quickly, both to you and your reader, than presenting the same information in a table.

Typically you use two levels of graphing in the lab. A graph that appears in your final report is a “higher-level” graph. Such a graph is done neatly (and almost always with a graphing program), following all the presentation guidelines listed below. It’s made primarily for the benefit of the person reading your report. “Lower-level” graphs are rough graphs that you make for your own benefit in the lab room; they’re the ones the lab assistants will hound you to construct. These lower-level graphs tell you when you need to take more data or check a data point. They’re most useful when you make them in time to act on them, which means that you should get in the habit of graphing your data in the lab while you still have access to the equipment. (That’s one reason, in fact, that we recommend that you leave every other sheet in your lab notebook free, so you can use that blank sheet to graph your data.) In graphing your data in the lab, you don’t need to be too fussy about taking up the whole page or making the divisions nice. You should label the axes and title the graph, though.

Flaky data points show up almost immediately in a graph, which is one reason to graph your data in the lab. Skipping this low-level graphing step can allow problems in the data collection to propagate undetected and require you to perform the experiment again from the beginning. Graphing each point as you take it is probably not the best idea, though. Doing so can be inefficient and may prejudice you about the value of the next data point. So your best bet is to take five or six data points and graph them all at once.

Graphing your data right away also flags regions in your data range where you should take more data. Typically people take approximately evenly-spaced data points over the entire range of the independent variable, which is certainly a good way to start. A graph of that “survey” data will tell you if there are regions where you should look more closely; regions where you graph is changing rapidly, going through a minimum or maximum, or changing curvature, for example. The graph helps you identify interesting sections where you should get more data, and saves you from taking lots of data in regions where nothing much is happening.

B.2 Analyzing your Graph

“Graphical data analysis” is usually a euphemism for “find the slope and intercept of a line.” You will find this semester that you spend a lot of time redrawing curves by employing the “method of straight line graphing” so that they turn into straight lines, for which you can calculate a slope and an intercept. This process is so important that, although we have a fond hope that you learned how to do this in high school, we’re going to review it anyway.

Presumably you have in front of you some graphed data that look pretty linear. Start by drawing in by eye the line that you think best represents the trend in your data. An analytical procedure exists to draw such a line, but in fact your eyeballed line will be pretty close to this analytically-determined “best” line. Your job now is to find the slope and intercept of that “best” line you’ve drawn.

Next we tackle the question of finding the slope and intercept of that line. As usual, we will assume that the line is described by the equation

$$y = mx + b \tag{B.1}$$

where m is the slope of the line and b is the y -intercept.

Two points determine a line, and a line is also described completely by its slope and intercept. (This should make a certain amount of sense. You put in two pieces of information, you get out two pieces of information.) Your first task is therefore to choose two points on your line. These two points describe the line, so they need not (and most likely *will* not) be data points. They should be far apart on the graph, to minimize the effects of the inevitable experimental uncertainty in reading their locations from the graph paper. The two points should also be located at easy-to-read crossings on the graph paper. Mark each of those points with a heavy (but not too large) dot and draw a circle around the dot. Read the coordinates of each point off the graph.

The slope of the line is defined as the change in y (the vertical coordinate) divided by the corresponding change in x (the horizontal coordinate). (You may know this in some other

form, such as “rise over run.”) To calculate the slope, use

$$\text{slope} = m = \frac{y_2 - y_1}{x_2 - x_1}, \quad (\text{B.2})$$

substituting your values for the points (x_1, y_1) and (x_2, y_2) . For example, if your points are (1.0 sec, 8.8 m/sec) and (6.0 sec, 46.3 m/sec), then $m = 7.5 \text{ m/sec}^2$. (Notice that the units of m are the units of “rise-over-run.”) Now that you have the slope, find the intercept from

$$\text{intercept} = b = y_1 - mx_1. \quad (\text{B.3})$$

That is, you can read b directly off the graph, or you can use the slope and one point to determine b . Use either point for (x_1, y_1) . Both lie on the line, so either will work. In the example above, we get that $b = 1.3 \text{ m/sec}$. (Notice that the units of b are those of the y variable.)

Once you have determined the values of m and b from the graph, you can quote the equation for your straight line. For example, if $m = 7.5 \text{ m/sec}^2$ and $b = 1.3 \text{ m/sec}$, then the equation of your straight line is

$$y = (7.5 \text{ m/sec}^2)x + 1.3 \text{ m/sec}. \quad (\text{B.4})$$

This equation gives a **complete** description of the line and the job is done.

B.3 Uncertainty Bars

Individual data points plotted on any graph should include uncertainty bars (sometimes misleadingly called “error bars”) showing the uncertainty range associated with each data point. You should show both vertical and horizontal uncertainty bars, if the uncertainties are large enough to be visible on the graph. (If they aren’t large enough, you should mention this in your report so we don’t think you’ve forgotten them.) You can draw uncertainty bars by indicating the “best guess” value (typically the measured value or average of several measurements) with a dot, and drawing an “I-bar” through the dot with its length indicating the range in the uncertainty. When you use Excel or the Graphical Analysis data analysis package, this step can be done for you — with severe limitations. Such a package will typically only determine error bars by considering the scatter of the individual data points about the best-fit straight line. While this is helpful in providing a consistency check for the data, it does not tell the complete story of the uncertainties in your data. That is, unless you use a more advanced feature of such an analysis program, it has no way of knowing about the uncertainties that were inherent in your measured values because of the measurement apparatus. Only you can decide how accurately you used the meter stick, or how quickly you were able to react when starting and stopping a stopwatch. You will not always be expected to put error bars on all of your plotted points, but you should know how it is done and be able to apply it to the first lab.

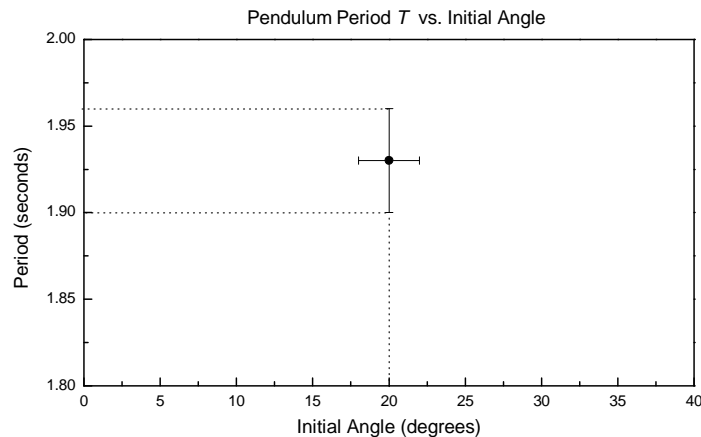

Figure B.1. A graph of one data point of the pendulum period as a function of angle, showing uncertainty bars for both variables.

An example of such an uncertainty bar is shown in Fig. B.1, below. The single data point plotted corresponds to a measured pendulum period T of $1.93 \text{ sec} \pm 0.03 \text{ s}$ for an initial release angle θ of $20^\circ \pm 2^\circ$. The dotted lines are not part of the graph, but are included to show you how the point and the uncertainty bars are related to the axes. (Notice also that the T -axis does not begin at $T = 0$.)

B.4 Presentation Guidelines

Use these guidelines for “higher-level” graphs.

1. Draw your hand-plotted graphs in pencil; mistakes are easy to make. If you wish, go back later and touch them up in ink. Computer-drawn graphs are fine as long as they comply with the remaining guidelines.
2. Scale your axes to take the best possible advantage of the graph paper. That is, draw as large a graph as possible, but the divisions of the graph paper should correspond to some nice interval like 1, 2, or 5 (times some power of 10). If you have to make the graph smaller to get a nice interval, make it smaller, but check that you’ve picked the nice interval that gives you the largest graph. Making the graph large will display your data in as much detail as possible. When using log-log or semi-log paper, choose paper with the number of cycles that gives the largest possible graph.
3. The lower left-hand corner need not be the point $(0,0)$. Choose the range of values for each axis to be just wide enough to display all the data you want. If $(0,0)$ does not appear on the graph, it’s customary (but not necessary) to mark the break in the axis with two wavy lines (\approx).

4. Mark the scale of each axis (the number of units corresponding to each division) for the entire length of the axis.
5. Label both axes, identifying the quantity being plotted on each axis *and* the units being used.
6. Give each graph a title or provide a figure caption. The title should summarize the information contained in the axes and also gives any additional information needed to distinguish this graph from other graphs in the report.
7. Give each graph a number (e.g., “Figure 2”), which you can use in the body of the report to refer quickly to the graph.
8. If you calculate the slope and intercept of the graph from two points (rather than using linear regression), indicate the two points you used on the graph. Draw the line through the two points, label it “Best-fit line” (or something similar), and give its slope and intercept on the graph in some large clear space.

Graphing Checklist

- Axes scaled correctly with divisions equal to “nice” intervals;
- Graph drawn to as large a scale as possible;
- Scales on axes labeled for entire length;
- Axes labeled, including units;
- Graph titled and numbered; and
- Points used to calculate slope and intercept clearly marked, if that method is used.

Appendix C

Uncertainty Analysis

An intrinsic feature of every measurement is the uncertainty associated with the result of that measurement. No measurement is ever exact. Being able to determine and assess measurement uncertainties intelligently is an important skill in any type of scientific work. The measurement (or experimental) uncertainty should be considered an *essential* part of every measurement.

Why make such a fuss over measurement uncertainties? Indeed, in many cases the uncertainties are so small that, for some purposes, we needn't worry about them. On the other hand, there are many situations in which small changes might be very significant. A clear statement of measurement uncertainties helps us assess deviations from expected results. For example, suppose that two scientists report measurements of the speed of light (in vacuum). Scientist Curie reports 2.99×10^8 m/s. Scientist Wu reports 2.98×10^8 m/s. There are several possible conclusions we could draw from these reported results:

1. These scientists have discovered that the speed of light is not a universal constant.
2. Curie's result is better because it agrees with the "accepted" value for the speed of light.
3. Wu's result is worse because it disagrees with the accepted value for the speed of light.
4. Wu made a mistake in measuring the speed of light.

Without knowing the uncertainties in these measurements, however, it turns out that we cannot assess the results at all!

C.1 Expressing Experimental Uncertainties

Suppose that we have measured the distance between two points on a piece of paper. There are two common ways of expressing the uncertainty associated with this measurement:

C.1.1 Absolute Uncertainty

We might express the result of the measurement as

$$5.1 \text{ cm} \pm 0.1 \text{ cm}. \quad (\text{C.1})$$

By this we mean that the result (usually an average result) of the set of measurements is 5.1 cm, but given the conditions under which the measurements were made, the fuzziness of the points, and the refinement of our distance measuring equipment, it is our best judgment that the “actual” distance might lie between 5.0 cm and 5.2 cm.

Incidentally, an alternative (shorthand) way of expressing this uncertainty looks like this:

$$5.1(1) \text{ cm} \quad (\text{C.2})$$

where the number in parentheses represents the uncertainty in the last digit. Feel free to use this form in your lab work.

C.1.2 Relative (or Percent) Uncertainty

We might express the same measurement result as

$$5.1 \text{ cm} \pm 2\%. \quad (\text{C.3})$$

Here the uncertainty is expressed as a percentage of the measured value.

Both means of expressing uncertainties are in common use and, of course, express the same uncertainty.

An aside on significant figures

The number of significant figures quoted for a given result should be consistent with the uncertainty in the measurement. In the example, it would be inappropriate to quote the results as 5 cm ± 0.1 cm (too few significant figures in the result) or as 5.132 cm ± 0.1 cm (too many significant figures in the result). Some scientists prefer to give the best estimate of the next significant figure after the one limited by the uncertainty; for example, 5.13 cm ± 0.1 cm. The uncertainties, since they are estimates, are usually quoted with only one significant figure; in some cases, *e.g.*, for very high precision measurements, the uncertainties may be quoted with two significant figures.

C.2 Determining Experimental Uncertainties

There are several methods for determining experimental uncertainties. Here we mention three methods, which can be used easily in most of the laboratory measurements in this course.

C.2.1 Estimate Technique

In this method, we estimate the precision with which we can measure the quantity of interest, based on an examination of the measurement equipment (scales, balances, meters, etc.) being used and the quantity being measured (which may be “fuzzy,” changing in time, etc.). For example, if we were using a scale with 0.1 cm marks to measure the distance between two points on a piece of paper, we might estimate the uncertainty in the measured distance to be about ± 0.05 cm, that is, we could easily estimate the distance to within $\pm \frac{1}{2}$ of a scale marking.

C.2.2 Sensitivity Estimate

Some measurements are best described as comparison or “null” measurements, in which we balance one or more unknowns against a known quantity. For example, in the Wheatstone bridge experiment, we will determine an unknown resistance in terms of a known precision resistance by setting a certain potential difference in the circuit to zero. We can estimate the uncertainty in the resulting resistance by slightly varying the precision resistor to see what range of resistance values leads to a “balanced” bridge within our ability to check for zero potential difference.

C.2.3 Repeated Measurement (Statistical) Technique

If a measurement is repeated in independent and unbiased ways, the results of the measurements will be slightly different each time. A statistical analysis of these results then, it is generally agreed, gives the “best” value of the measured quantity and the “best” estimate of the uncertainty to be associated with that result. The usual method of determining the best value for the result is to compute the “mean value” of the results: If x_1, x_2, \dots, x_N are the N results of the measurement of the quantity x , then the mean value of x , usually denoted \bar{x} , is defined as

$$\bar{x} \equiv \frac{x_1 + x_2 + \cdots + x_N}{N} = \frac{1}{N} \sum_{i=1}^N x_i. \quad (\text{C.4})$$

The uncertainty in the result is usually expressed as the “root-mean-squared deviation” (also called the “standard deviation”) usually denoted as δx (read “delta x ”). [Note that here δx does not mean the change in x , but rather is a measure of the spread in x values in the set of measurements.] Formally, the standard deviation is computed as

$$\delta x = \sqrt{\frac{(x_1 - \bar{x})^2 + \cdots + (x_N - \bar{x})^2}{N - 1}} \quad (\text{C.5})$$

Although determining the standard deviation may be tedious for a large array of data, it is generally accepted as the “best” estimate of the measurement uncertainty.

N.B.: In general, we cannot expect exact agreement among the various methods of determining experimental uncertainties. As a rule of thumb, we usually expect the different methods of determining the uncertainty to agree within a factor of two or three.

EXAMPLE

Suppose that five independent observers measure the distance between two rather fuzzy marks on a piece of paper and obtain the following results:

$$d_1 = 5.05 \text{ cm}$$

$$d_2 = 5.10 \text{ cm}$$

$$d_3 = 5.15 \text{ cm}$$

$$d_4 = 5.20 \text{ cm}$$

$$d_5 = 5.10 \text{ cm}$$

If the observers were using a scale with 0.1 cm markings, method 1) would suggest an uncertainty estimate of about ± 0.05 cm. Method 3) yields a mean value $d = 5.12$ cm and for the standard deviation $0.057 \text{ cm} \sim 0.06 \text{ cm}$. We see that in this case we have reasonable agreement between the two methods of determining the uncertainties. We should quote the result of this measurement as $5.12 \text{ cm} \pm 0.06 \text{ cm}$ or $5.12 \text{ cm} \pm 1\%$.

C.3 Propagation of Uncertainties

In most measurements some calculation is necessary to link the measured quantities to the desired result. The question then naturally arises: How do the uncertainties in the measured quantities affect (propagate to) the results? In other words, how do we estimate the uncertainty in the desired result from the uncertainties in the measured quantities?

C.3.1 “High-Low” Method

One way to do this is to carry through the calculation using the extreme values of the measured quantities, for example 5.06 cm and 5.18 cm from the previous example, to find the range of result values. This method is straightforward but quickly becomes tedious if several variables are involved.

EXAMPLE

Suppose that you wish to determine a quantity, X , which is to be calculated indirectly using the measurements of a , b , and c , together with a theoretical expression: $X = \frac{ab}{c}$.

Suppose, further, that you have already determined that

$$\begin{aligned} a &= 23.5 \pm 0.2 \text{ m} \\ b &= 116.3 \pm 1.1 \text{ N} \\ c &= 8.05 \pm 0.03 \text{ s} \end{aligned}$$

The “best” value of X is

$$X_{\text{best}} = \frac{23.5 \times 116.3}{8.05} = 339.509 \text{ N} \cdot \text{m/s} \quad (\text{C.6})$$

(We’ll clean up the significant figures later.)

But X could be about as large as what you get by using the maximum values of a and b and the minimum (why?) value of c :

$$X_{\text{high}} = \frac{23.7 \times 117.4}{8.02} = 346.930 \text{ N} \cdot \text{m/s}. \quad (\text{C.7})$$

And similarly, we find

$$X_{\text{low}} = \frac{23.3 \times 115.2}{8.08} = 332.198 \text{ N} \cdot \text{m/s}. \quad (\text{C.8})$$

Notice that X_{high} and X_{low} differ from X_{best} by about the same amount (7.3). Also note that it would be silly to give six significant figures for X . Common sense suggests reporting the value of X as, say, $X = 339.5 \pm 7.3 \text{ N} \cdot \text{m/s}$, or $X = 339 \pm 7 \text{ N} \cdot \text{m/s}$.

C.3.2 General Method

The general treatment of the propagation of uncertainties is given in detail in texts on the statistical analysis of experimental data. A particularly good reference at this level is

Taylor [1]. Here we will develop a very simple, but general method for finding the effects of uncertainties.

Suppose we want to calculate some result R , which depends on the values of several measured quantities x , y , and z :

$$R = f(x, y, z) \quad (\text{C.9})$$

Let us also suppose that we know the mean values and standard deviations for each of these quantities. Then the uncertainty in R due to the uncertainty in x , for example, is calculated from

$$\delta_x R = \left(\frac{\partial}{\partial x} f(\bar{x}, \bar{y}, \bar{z}) \right) \delta x \quad (\text{C.10})$$

where the subscript on δ reminds us that we are calculating the effect due to x alone. Note that the partial derivative is evaluated with the mean values of the measured quantities. In a similar fashion, we may calculate the effects due to δy and δz .

N.B. By calculating each of these contributions to the uncertainty individually, we can find out which of the variables has the largest effect on the uncertainty of our final result. If we want to improve the experiment, we then know how to direct our efforts.

We now need to combine the individual contributions to get the overall uncertainty in the result. The usual argument is the following: If we assume that the variables are independent so that variations in one do not affect the variations in the others, then we argue that the net uncertainty is calculated as the square root of the sum of the squares of the individual contributions:

$$\delta R = \sqrt{(\delta_x R)^2 + (\delta_y R)^2 + (\delta_z R)^2} \quad (\text{C.11})$$

The formal justification of this statement comes from the theory of statistical distributions and assumes that the distribution of successive measurement values is described by the so-called Gaussian (or equivalently, normal) distribution.

In rough terms, we can think of the fluctuations in the results as given by a kind of “motion” in a “space” of variables x , y , and z . If the motion is independent in the x , y , and z directions, then the net “speed” is given as the square root of the sum of the squares of the “velocity” components. In most cases, we simply assume that the fluctuations due to the various variables are independent and use Eq. C.11 to calculate the net effect of combining the contributions to the uncertainties.

Note that our general method applies no matter what the functional relationship between R and the various measured quantities. It is not restricted to additive and multiplicative relationships as are the usual simple rules for handling uncertainties.

In most cases, we do not need extremely precise values for the partial derivatives, and we may compute them numerically. For example,

$$\frac{\partial f}{\partial x} = \frac{f(\bar{x} + \delta x, \bar{y}, \bar{z}) - f(\bar{x}, \bar{y}, \bar{z})}{\delta x} \quad (\text{C.12})$$

Connection to the traditional simple rules

To see where the usual rules for combining uncertainties come from, let's look at a simple functional form:

$$R = x + y \quad (\text{C.13})$$

Using our procedure developed above, we find that

$$\delta_x R = \delta x, \delta_y R = \delta y \quad (\text{C.14})$$

and combining uncertainties yields

$$\delta R = \sqrt{(\delta x)^2 + (\delta y)^2} \quad (\text{C.15})$$

The traditional rule for handling an additive relationship says that we should add the two (absolute) uncertainty contributions. We see that the traditional method overestimates the uncertainty to some extent.

Exercise: Work out the result for a multiplicative functional relationship $R = f(x, y) = xy$. Compare our method with the traditional method of “adding relative uncertainties.”

Example

Suppose we have made some measurements of a mass m , a distance r , and a frequency f , with the following results for the means and standard deviations of the measured quantities:

$$m = 150.2 \pm 0.1$$

$$r = 5.80 \pm 0.02$$

$$f = 52.3 \pm 0.4$$

(Note that we have omitted the units and hence lose 5 points on our lab report.)

From these measured values we want to determine the “best value” and uncertainty for the following computed quantity:

$$F = mr f^2 \quad (\text{C.16})$$

The “best value” is computed by simply using the best values of m , r , and f : $F = 2382875.2$ (we'll tidy up the number of significant figures later on).

Let's use our partial derivative method to find the uncertainty. First, let's determine the effect to to m :

$$\delta_m F = \left(\frac{\partial F}{\partial m} \right) \delta m = r f^2 \delta m = 1586 \quad (\text{C.17})$$

Next, we look at the effect of r :

$$\delta_r F = \left(\frac{\partial F}{\partial r} \right) \delta r = m f^2 \delta r = 8217 \quad (\text{C.18})$$

And finally, the effect of f is given by

$$\delta_f F = \left(\frac{\partial F}{\partial f} \right) \delta f = 2 m r f \delta f = 36449 \quad (\text{C.19})$$

We see immediately that the measurement of f has the largest effect on the uncertainty of F . If we wanted to decrease the uncertainty of our results, we ought to work hardest at decreasing the uncertainty in f .

Finally, let's combine the uncertainties using the "square root-of-the-sum-of-the-squares" method. From that computation we find that we ought to give F in the following form:

$$F = (2.383 \pm 0.037) \times 10^6 \quad (\text{C.20})$$

or

$$F = (2.38 \pm 0.04) \times 10^6 \quad (\text{C.21})$$

in the appropriate units. Note that we have adjusted the number of significant figures to conform to the stated uncertainty. As mentioned above, for most purposes, citing the uncertainty itself to one significant figure is adequate. For certain, high precision measurements, we might cite the uncertainty to two significant figures.

C.4 Assessing Uncertainties and Deviations from Expected Results

The primary reason for keeping track of measurement uncertainties is that the uncertainties tell us how much confidence we should have in the results of the measurements. If the results of our measurements are compared to the results expected on the basis of theoretical calculations or on the basis of previous experiments, we expect that, if no mistakes have been made, the results should agree with each other within the combined uncertainties. (Note that even a theoretical calculation may have an uncertainty associated with it because there may be uncertainties in some of the numerical quantities used in the calculation or various mathematical approximations may have been used in reaching the result.) There are several ways to assess whether our data support the theory we are trying to test.

C.4.1 Rule of Thumb

As a rule of thumb, if the measured results agree with the expected results within a factor of about two times the combined uncertainties, we usually can view the agreement as satisfactory. If the results disagree by more than about two times the combined uncertainties, something interesting is going on and further examination is necessary.

Example

Suppose a theorist from Harvard predicts that the value of X in the previous example should be $333 \pm 1 \text{ N} \cdot \text{m/s}$. Since our result ($339 \pm 7 \text{ N} \cdot \text{m/s}$) overlaps the theoretical prediction within the combined uncertainties, we conclude that there is satisfactory agreement between the measured value and the predicted value given the experimental and theoretical uncertainties. However, suppose that we refine our measurement technique and get a new result $340.1 \pm 0.1 \text{ N} \cdot \text{m/s}$. Now the measured result and the theoretical result do not agree. [Note that our new measured result is perfectly consistent with our previous result with its somewhat larger uncertainty.] We cannot tell which is right or which is wrong without further investigation and comparison.

C.4.2 χ^2 (Statistical) Technique

The χ^2 technique produces a number which tells you how well your data match the theory you are trying to test. Let's imagine that we have a theory which suggests that two measured variables x and y are related: $y = y(x)$. As a test of this theory let's further imagine that we do an experiment which generates x_i and $y_i \pm \sigma_i$. We are assuming here that the error in the x_i is negligibly small. The χ^2 for this data set is given by

$$\chi^2 = \sum_{i=1}^N \left\{ \frac{[y_i - y(x_i)]^2}{\sigma_i^2} \right\} \quad (\text{C.22})$$

where N is the number of data points. The reduced χ^2 , written χ_ν^2 , is defined by

$$\chi_\nu^2 \equiv \frac{\chi^2}{\nu} \quad (\text{C.23})$$

where $\nu = N - n$ and n is the number of free parameters in the fit. (A straight-line fit has two free parameters, the slope and the intercept.)

Despite its appearance, χ_ν^2 is fairly easy to interpret. To see this, let's consider a large set of data with only a small number of free parameters so that $\nu \approx N$. If the data fit well to the theory then we would expect, on average, that $[y_i - y(x_i)]^2 \approx \sigma_i^2$. Thus, we would also expect that $\chi^2 \approx N$ and therefore $\chi_\nu^2 \approx 1$. If, on the other hand, our theory doesn't fit the data well, we would expect $[y_i - y(x_i)]^2 > \sigma_i^2$ on average and, therefore, $\chi_\nu^2 > 1$. If we have overestimated our errors or chosen too many free parameters then $[y_i - y(x_i)]^2 < \sigma_i^2$ on average, and $\chi_\nu^2 < 1$. A full analysis of this technique is given in Bevington [2]. In practice this is a difficult technique to apply with any rigor because estimating errors is so difficult. For the purposes of this course we will call any fit with $0.5 < \chi_\nu^2 < 2$ a good fit.

C.5 The User's Guide to Uncertainties

The rules can be derived using the results of Sec. C.3.2.

C.5.1 Addition and Subtraction

For addition and subtraction one should combine the absolute uncertainties in the measured quantities. Typically, one calculates the final uncertainty by adding the uncertainties in quadrature, which means taking the square root of the sums of the squares. For example, the quadrature sum of the three uncertainties δx_1 , δx_2 , and δx_3 is

$$\delta x_{\text{total}} = \sqrt{(\delta x_1)^2 + (\delta x_2)^2 + (\delta x_3)^2}. \quad (\text{C.24})$$

The following simple example shows how to propagate uncertainties for the case of a simple sum.

Example 1: Alice measures the lengths of the sides of a triangle, finding $s_1 = 2.9 \pm 0.2$ cm, $s_2 = 4.2 \pm 0.4$ cm, and $s_3 = 4.9 \pm 0.1$ cm. What is the perimeter of the triangle and Alice's uncertainty in its value?

Answer: The equation for the perimeter is $P = s_1 + s_2 + s_3 = 12.0$ cm. The final uncertainty in its value is found by summing the individual errors in quadrature:

$$\delta P = \sqrt{(\delta s_1)^2 + (\delta s_2)^2 + (\delta s_3)^2} = 0.5 \text{ cm}. \quad (\text{C.25})$$

The value Alice should quote for the perimeter is therefore $P = 12.0 \pm 0.5$ cm.

C.5.2 Multiplication and Division

For multiplication and division, uncertainties propagate in a slightly different manner. One must first calculate the fractional uncertainty of a quantity. If some value q has an associated uncertainty δq , then

$$\text{fractional uncertainty} \equiv \frac{\delta q}{q} \quad (\text{C.26})$$

Once we know the fractional uncertainties for each measured quantity in the product or quotient, we can add them in quadrature to get the fractional uncertainty of the result. To get the absolute uncertainty of the result, simply multiply the fractional uncertainty by the result.

Example 2: Bob wants to find the area of a triangle. He knows the length of the base $b = 4.2 \pm 0.2$ cm and the height $h = 5.8 \pm 0.1$ cm. What is the area of Bob's triangle?

Answer. The equation for the area is $A = \frac{1}{2}bh = 12.2 \text{ cm}^2$. The final uncertainty in the result is found by summing the fractional errors in quadrature, and then multiplying by the result:

$$\delta A = A \sqrt{\left(\frac{\delta b}{b}\right)^2 + \left(\frac{\delta h}{h}\right)^2} = 0.6 \text{ cm}^2. \quad (\text{C.27})$$

Bob should quote his total area as $A = 12.2 \pm 0.6 \text{ cm}^2$.

C.5.3 Multiple Operations

For combinations of operations, the best approach is to break the problem up into pieces that can be solved by using the rules given above, and then combine the uncertainties of each of these pieces appropriately. The following example should make it clear how one can go about finding the final uncertainty in a more complicated problem.

Example 3. Cassandra wishes to know the speed of a cart traveling along a (level) air track. She measures the distance of two photogates from the end of the air track ($d_1 = 18.4 \pm 0.2 \text{ cm}$ and $d_2 = 160.1 \pm 0.3 \text{ cm}$), and also the times at which the cart triggers each photogate ($t_1 = 0.53 \pm 0.01 \text{ s}$ and $t_2 = 1.88 \pm 0.02 \text{ s}$). What is the speed of the cart and the uncertainty that Cassandra should quote?

Answer: The expression for the speed is, of course,

$$v = \frac{d_2 - d_1}{t_2 - t_1} \quad (\text{C.28})$$

First, we compute the numerator and its uncertainty:

$$d_2 - d_1 = 141.7 \pm 0.4 \text{ cm} \quad (\text{C.29})$$

where we applied the rules for addition and subtraction (add absolute uncertainties in quadrature). We now do a similar calculation for the denominator:

$$t_2 - t_1 = 1.35 \pm 0.02 \text{ s}. \quad (\text{C.30})$$

Finally, we calculate v , using the rules for multiplication and division on the uncertainties in Eqs. C.29 and C.30 (add fractional uncertainties in quadrature):

$$v = \frac{141.7 \pm 0.4 \text{ cm}}{1.35 \pm 0.02 \text{ s}} = 105 \pm 2 \text{ cm/s}. \quad (\text{C.31})$$

Bibliography

- [1] J. R. Taylor. *An Introduction to Error Analysis*. University Science Books, Sausalito, California, second edition, 1997.
- [2] P. R. Bevington and D. K. Robinson. *Data Reduction and Error Analysis for the Physical Sciences*. McGraw-Hill, New York, second edition, 1992.